

Icosahedron Array FEA Modeling

February 19, 2008

VGO Project #07093

Prepared For:

**Attn: Sam Lanahan
Flextegrity
2043 NW Johnson St.
Portland, OR 97209**

VGO Testing & Inspection
Engineers

10220 SW Nimbus, Suite K/10
Portland, OR 97223
Tel (503)968-6391
Fax (503)968-6393

TABLE OF CONTENTS

Background	1
Purpose	1
Methodology	2
Results	7
Discussion	9
Recommendations	10
Appendix A Array Dimensions	A
Appendix B Scenario 1-12 Results	B
Appendix C Scenario 13-14 Results	C
Appendix D Select Graphical Results	D

Background

Flextegrity is in the process of developing an innovative macroscopic composite material which can be used to engineer desired bulk properties for a variety of applications. This material is made up of individual icosahedron elements which are interconnected by a series of springs.

Several icosahedron array (ICA) implementations with differing geometry and materials have been produced and some physical testing has been performed.

Purpose

VGO Inc. Engineering was retained to produce a series of FEA models to characterize how changes to specific parameters of the array affect the deflection under specified loading.

Particularly the following parameters were to be modified:

- 1) Thickness of the array (Height, # of IC elements)
- 2) Axial stiffness of the springs (Axial K, lbf/in)
- 3) Radius of the Icosahedron (r, inches)
- 4) Angle of the spring elements (θ , degrees)
- 5) Weave Type (Bias or Perpendicular)

In addition, Flextegrity wanted to determine, based on this initial work, a set of ICA parameters which would yield a deflection of less than 0.5 inches under a 2500 lbf distributed load for a particular set of constraints.

Methodology

The ICA's are made up of a series of spring connected icosahedron elements, as depicted in Figure 1.

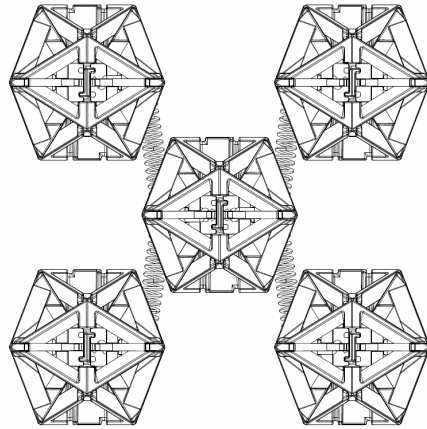

Figure 1 – 2-D Flat pattern of IC array

When this geometry is assembled into a large 3-dimensional array, the number of icosahedron components and spring components becomes large. With the complex geometry of the solid IC components, solid element modeling becomes computationally cost prohibitive. Additionally, modeling of springs using solid elements is problematic. For these reasons, this study was performed using beam elements to simulate structural components. Figure 2 shows the springs in blue and the icosahedron placeholders as black.

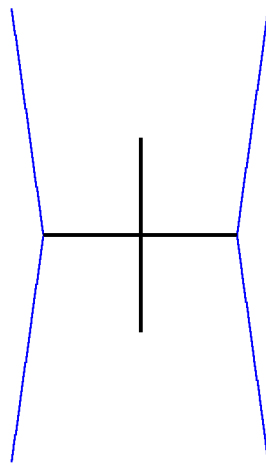

Figure 2 – 2-D Flat pattern of IC array

Initial estimates placed the axial stiffness of the springs at around 20 lbf/in, while the icosahedrons at around 700 lbf/in. Since the stiffness of the icosahedrons

was far greater than the stiffness of the springs an approximation was made to consider the icosahedrons as rigid and base the performance of the arrays on the spring stiffness alone. This type of assumption is common in structural mechanics problems where minor effects are neglected to aide in modeling. This assumption produces a model where by the effect of the springs alone can be determined. Real-world performance of the arrays depicted will likely include a slight increase in deflection due to the rigid element deformation.

Stiffness determination

Accuracy of the models depend on generating stiffness relationships that correspond to the mechanical elements being modeled. In order to produce a desired stiffness in the elements, the calculations are performed to determine cross sectional properties that will produce the desired stiffness.

For the rigid elements (icosahedrons) this is a simple task. All that is required is to choose cross sectional properties that are far stiffer than the rest of the elements in the model. Since we are working on the assumption that the rigid elements are far stiffer than the surrounding springs, and that their deflection is negligible, we choose a stiff cross section. Ideally, we would choose an infinite stiffness, but computationally it makes more sense to choose a manageable figure. For the purpose of this study, the rigid elements were arbitrarily given the cross sectional properties (A, I, and J) of a 1.0 inch round solid steel rod ($E=30e6\text{psi}$, $\nu=0.3$).

Spring stiffness was more complex to determine, as it needed to be controlled and varied precisely. To accomplish this, we first need to be aware of the geometric cross sectional properties that affect the model.

- A = cross sectional area (in^2), used to compute the axial stiffness
- J = polar moment of inertia (in^4), used to compute the torsional stiffness
- I = moment of inertia (in^4), used to compute the bending stiffness

In addition to cross sectional properties, material properties also play a role in determining stiffness:

- E = modulus of elasticity (psi), a materials inherent geometrically independent spring rate, axially loaded
- ν = poisson's ratio (unit-less), the relationship between the lateral strain and axial strain
- G = shear modulus (psi), a materials inherent geometrically independent spring rate, shear loaded, related to E by: $E=2G(1+\nu)$

By manipulating the above parameters, beam elements can be made to exhibit any desired axial, torsional, and bending stiffness.

Beam stiffness is defined by the equations:

$$d = \frac{FL}{AE} \quad \text{and} \quad \theta = \frac{TL}{GJ} \quad \text{and} \quad y = \frac{FbL^3}{3EI}$$

Where:

- d = axial deflection (in)
- F = applied axial force (lbf)
- L = length of member (inch)
- A = cross sectional area (in²)
- E = modulus of elasticity (psi)
- θ = twist angle (radians)
- T = applied torque (in-lb)
- G = shear modulus (psi)
- J = polar moment of inertia (in⁴)
- y = bending deflection (in)
- Fb = bending force (lbf)
- I = modulus of elasticity (in⁴)

Initial stiffness was estimated for the springs. These estimates are approximate and should not be considered representative of any particular physical model. Since these values are known to be slightly in error, the absolute deflection values will be in error. This will not however affect the ability to make relative inferences about the effect of changing parameters.

The base case stiffness was axial=23.4 lbf/in, torsional=0.0188 in-lb/degree, and bending=0.8 lbf/in. Calculations were performed to determine appropriate A, J, and I values to generate this stiffness profile. The particular values used are detailed in Appendix B and C.

Material properties were selected as E=30e6 psi and v=0.3.

Sensitivity Study

Twelve separate scenarios were run to comprise the sensitivity study, as shown in Table 1. Additional details are shown in Appendix B.

**Table 1 – Sensitivity Study Matrix
07093 - FEA Scenarios 1-12**

Study	Scenario	Array Type	Height (IC's)	axial K (lbf/in)	r (in)	θ (deg)	L (in)
Height	1	Perpendicular	9	23.4	0.900	8	2.115
	2	Perpendicular	6	23.4	0.900	8	2.115
	3	Perpendicular	12	23.4	0.900	8	2.115
Height	4	Bias-Weave	9	23.4	0.900	8	2.115
	5	Bias-Weave	6	23.4	0.900	8	2.115
	6	Bias-Weave	12	23.4	0.900	8	2.115
Stiffness	7	Bias-Weave	9	29.1	0.900	8	2.115
	8	Bias-Weave	9	17.5	0.900	8	2.115
Radius	9	Bias-Weave	9	23.4	1.125	8	2.644
	10	Bias-Weave	9	23.4	0.675	8	1.586
Angle	11	Bias-Weave	9	23.4	0.900	3	1.902
	12	Bias-Weave	9	23.4	0.900	13	2.402

Scenario 4 represents the base case, with the approximated stiffness values and geometry consistent with the drawings provided. From this base case, several permutations were made to control variables in order to determine how the change affects the performance of the model.

In each case the ICA pad was constructed as shown in Appendix A. The array was constrained against all motion at every rigid node which falls on the bottom surface of the model. Loading of 200 lbf was evenly distributed on all of the nodes from the 4 center most rigid elements which were coincident with the top surface, as shown in Appendix A.

Since the axial stiffness is a function of length, L, the area, A, was adjusted to maintain 23.4 lbf/in for each case. The bending and torsional parameters, J and I, were not altered. This will result in the length affecting both the torsional and bending stiffness, which were initially considered to be secondary effects.

For the geometric studies, scenarios 9-12, either r or θ were modified with the other parameter held as in the base case. This change necessitated changing the spring length, L, since the three are geometrically related by the equation:

$$L = \frac{-2r}{(\sin \theta - \cos \theta)}$$

2500 lbf Loading Study

Six separate models were run to comprise the 2500lbf loading study, as shown in Table 2. Additional details are shown in Appendix C.

Table 2 – 2500 lbf Loading Study Matrix

07093 - FEA Scenarios 13-14						
Study	Scenario	Stiffness Multiplier	Height (IC's)	Axial K (lbf/in)	Torsional K (in-lb/deg)	Bending K (lbf/in)
Thick Pad	13	1x	8	35.1	0.03	2.7
		20x	8	702.1	0.57	54.4
		25x	8	877.7	0.71	68.0
		30x	8	1053.2	0.85	81.6
Thin Pad	14	1x	4	35.1	0.03	2.7
		20x	4	702.1	0.57	54.4

All models in the study utilized $r = 0.600$ inch and $\theta = 8$ degrees, resulting in $L = 1.410$ inch. This geometry was specified by Flextegrity to generate a pad height of approx 5.5 inches. Pad size was chosen to approximate 12 inches by 12 inches, with the specified array geometry.

In each case the ICA pad was constructed as shown in Appendix A. The array was constrained against all motion at every rigid node which falls on the bottom surface of the model. Loading of 2500 lbf was evenly distributed on all of the nodes from the 13 center most rigid elements which were coincident with the top surface, as shown in Appendix A. This produced a loaded area of approximately 4.16 inches by 8.75 inches. This area was chosen to roughly approximate the contact area produced by a vehicle tire.

The stiffness of the spring elements (axial, torsion, and bending) was increased by a stiffness multiplier until a deformation of less than 0.5 inches was achieved.

This study describes one set of stiffness values that will yield the desired deformation under load. There are other combinations of parameters which will yield similar results.

Results

Sensitivity Study

Results of the sensitivity studies are shown in Table 3. Complete details are shown in Appendix B, with select model views shown in Appendix D.

Table 3 – Scenario 1-12 Results

07093 - FEA Results		
Study	Scenario	Deflection (in)
Height	1	2.94
	2	2.62
	3	3.10
Height	4	3.39
	5	3.13
	6	3.56
Stiffness	7	3.00
	8	3.98
Radius	9	4.59
	10	2.28
Angle	11	3.13
	12	3.70

The results of the sensitivity studies suggest that array height and spring angle have relatively small effects. Spring axial stiffness was shown to have a significant effect, with the most significant effect caused by the radius size.

The perpendicular array was approximately 15% stiffer than the bias-weave in the configurations tested.

2500 lbf Loading Study

Results of the 2500 lbf loading studies are shown in Table 4. Complete details are shown in Appendix C, with select model views shown in Appendix D.

Table 4 – Scenario 13-14 Results

07093 - FEA Results			
Study	Scenario	Stiffness Multiplier	Deflection (in)
2500 lbf thick	13	1x	13.09
		20x	0.65
		25x	0.52
		30x	0.44
2500 lbf thin	14	1x	7.87
		20x	0.39

Results of the modeling indicate that when the stiffness of the array is multiplied by 30 times, deflections under the 0.5 inch limit were obtained with the taller array. This same effect was produced in the smaller array with a stiffness increase of only 20 times.

Discussion

Some interesting points were noted during the modeling.

Bi-modal effect

A significant proportion of the total deflection was related to the localized response of the ICA. It is evident in the deflected FEA models that the majority of the deflection occurs within 2-3 icosahedrons of the loading. The remainder of the array then distributes the load, as in conventional materials.

Due to this response, it is likely that distributed loads would produce significantly less deflection.

Stiffness of Springs approaching IC stiffness.

During the sensitivity studies, the FEA models were constructed on the premise that the icosahedrons were far stiffer than the springs, and that the icosahedrons performance could be neglected. While this assumption is valid, for the 2500 lbf testing the spring stiffness was increased 30 times. This makes the springs nearly as stiff as the icosahedrons and the assumption is no longer valid for identical icosahedrons. In this scenario, the icosahedrons being modeled would also need to be increased in stiffness in order to produce consistent results. If this is not done, increased deflection would be seen.

Bending and Torsional Stiffness

Initial assessments suggested that the axial spring stiffness was the most important spring parameter. Due to this, the axial stiffness was corrected to maintain a constant stiffness with changing spring length. The torsional and bending stiffness was considered secondary and not adjusted for spring length. If the torsional or bending properties of the springs contribute significantly then corrections should be applied to make the results more meaningful.

Normalized on ICA not dimensions

In all of the sensitivity studies, the array size and load was normalized on icosahedron spacing, not dimensions (ie. The array was 16x16 IC's not 12 inches x 12 inches). As a result, changing the ICA geometry also had an effect on the load and restrain locations. While it is necessary to choose a standard convention for the purpose of modeling, one must be careful to apply the same convention when interpreting the results. The results are comparing similar arrays, not similar spatial dimensions.

Recommendations

Based on the modeling performed to date and the results obtained, additional work could be performed to answer outstanding questions and to better understand the nature of the ICA system.

Since the torsional and bending stiffness was not considered in this study we are unable to gage the importance of these modes to the overall deflection picture. Performing a sensitivity study of these two parameters would aide in answering their significance.

The input stiffness for the springs was estimated based on incomplete information. Accurate results could be obtained with careful testing of the springs. With proper input to the models, the model results can be compare to macroscopic lab testing of ICA's in order to demonstrate the validity of this modeling method.

Further details of our analysis and findings are shown in the following Appendices.

Dave Van Dyke, P.E.
Engineering Manager

Appendix A

Array Dimensions

8

7

6

5

4

3

2

1

D

C

B

A

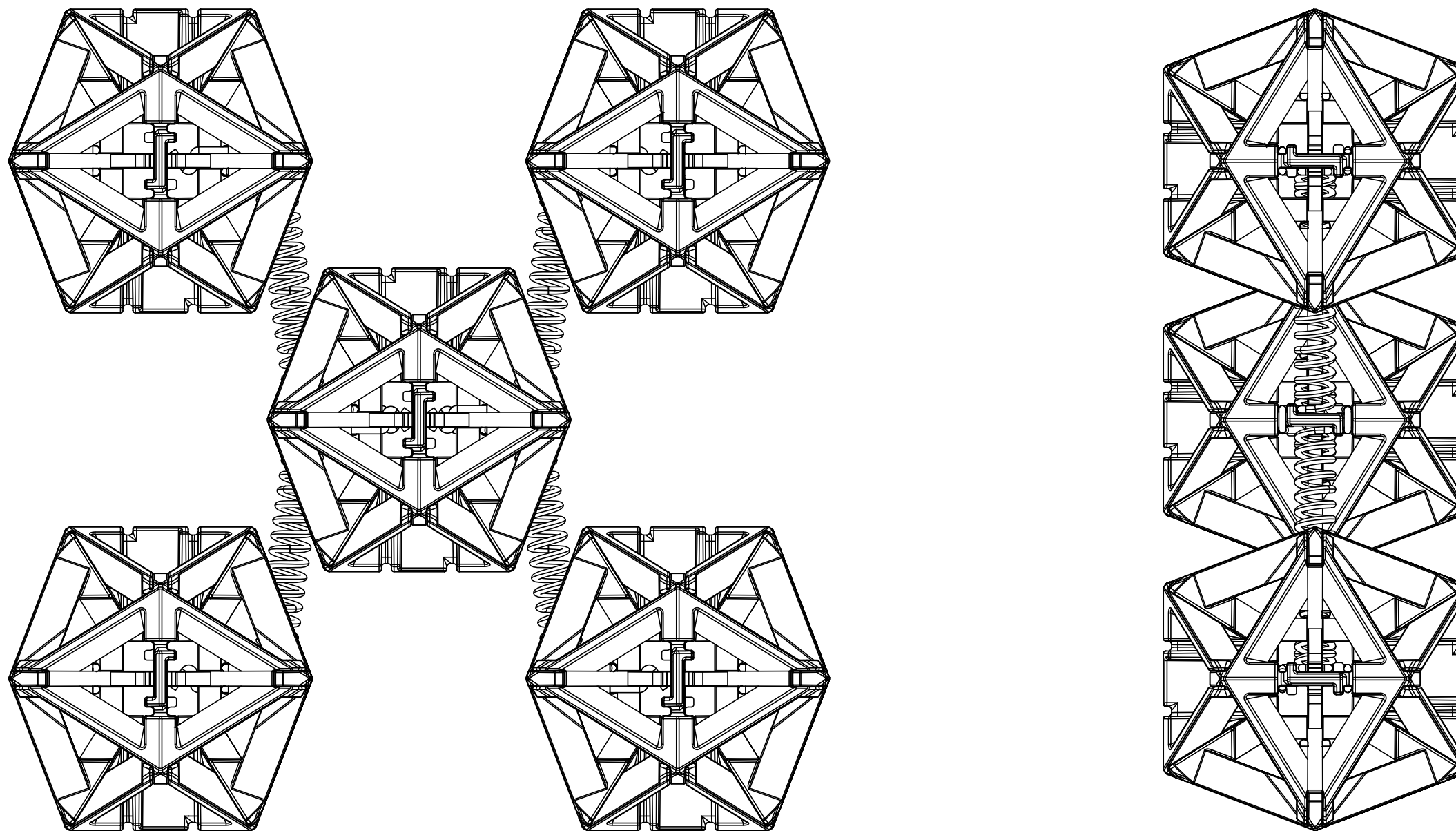

Note
 This drawing shows the general layout of the ICA components,
 comprised of ICA components and spring components.

PROPRIETARY AND CONFIDENTIAL
 THE INFORMATION CONTAINED IN THIS
 DRAWING IS THE SOLE PROPERTY OF
 VGO, Inc. ANY REPRODUCTION IN PART
 OR AS A WHOLE WITHOUT THE WRITTEN
 PERMISSION OF VGO, Inc. IS PROHIBITED.

		UNLESS OTHERWISE SPECIFIED:		NAME	DATE	 10220 SW Nimbus, STE K/10, Portland, OR (503)968-6391 TITLE: <h3 style="text-align: center;">Assembly 1</h3> Flextegrity		
		DIMENSIONS ARE IN INCHES		DRAWN	DMV			2-18-08
		TOLERANCES:		CHECKED				
		FRACTIONAL ± 1/16"		ENG APPR.				
		ANGULAR: MACH ± 1 BEND ± 1		MFG APPR.				
		TWO PLACE DECIMAL ±0.010		Q.A.				
		THREE PLACE DECIMAL ±0.002		COMMENTS:				
		INTERPRET GEOMETRIC TOLERANCING PER:						
		MATERIAL						
		FINISH						
NEXT ASSY	USED ON					SIZE	DWG. NO.	REV
						B	07093-500	-
						SCALE: 1:1	WEIGHT:	SHEET 1 OF 9

D

C

B

A

8

7

6

5

4

3

2

1

A1

8

7

6

5

4

3

2

1

D

D

C

C

B

B

A

A

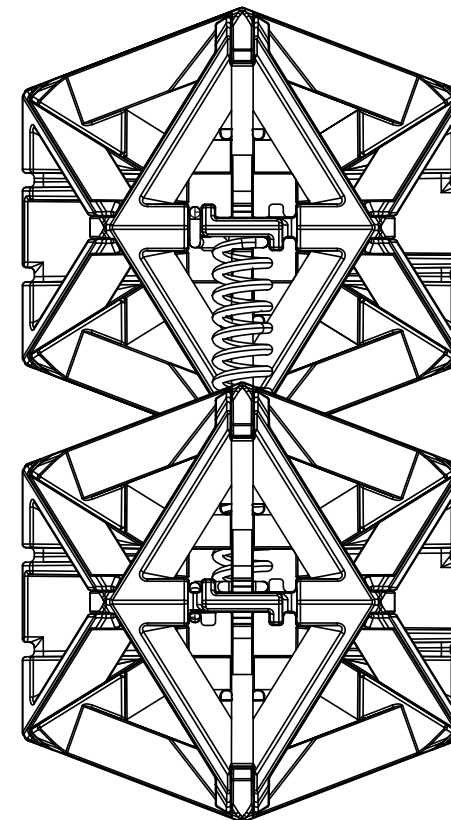
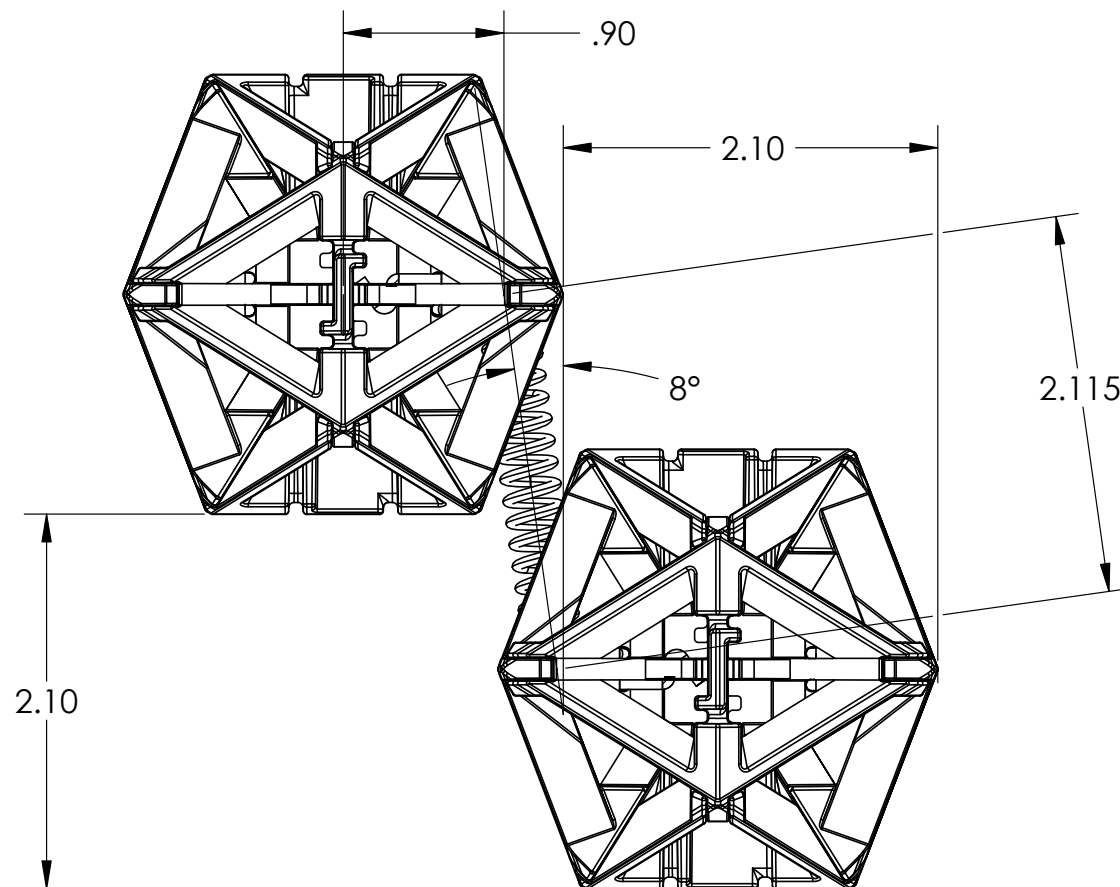
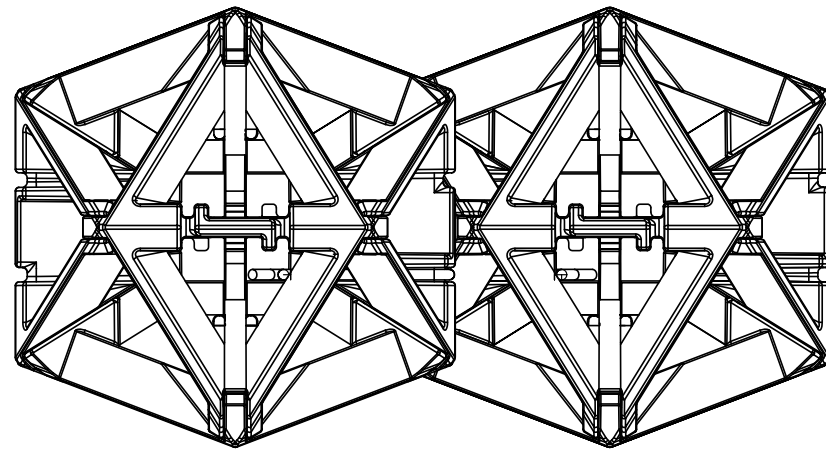

Note
This drawing shows the general layout of the ICA components, with associated dimensions. This configuration represents the base case from which the design was altered to determine response.

PROPRIETARY AND CONFIDENTIAL
THE INFORMATION CONTAINED IN THIS DRAWING IS THE SOLE PROPERTY OF VGO, Inc. ANY REPRODUCTION IN PART OR AS A WHOLE WITHOUT THE WRITTEN PERMISSION OF VGO, Inc. IS PROHIBITED.

		UNLESS OTHERWISE SPECIFIED:		NAME	DATE
		DIMENSIONS ARE IN INCHES		DRAWN	DMV
		TOLERANCES:		CHECKED	2-18-08
		FRACTIONAL ± 1/16"		ENG APPR.	
		ANGULAR: MACH ± 1 BEND ± 1		MFG APPR.	
		TWO PLACE DECIMAL ±0.010		Q.A.	
		THREE PLACE DECIMAL ±0.002		COMMENTS:	
		INTERPRET GEOMETRIC TOLERANCING PER:			
		MATERIAL			
		FINISH			
NEXT ASSY	USED ON				
APPLICATION		DO NOT SCALE DRAWING			

VGO Testing & Inspection Engineers
10220 SW Nimbus, STE K/10, Portland, OR (503)968-6391

TITLE:
Assembly Dimensions
Flextegrity

SIZE	DWG. NO.	REV
B	07093-500	-

SCALE: 1:1 | WEIGHT: | SHEET 2 OF 9

8

7

6

5

4

3

2

1

D

C

B

A

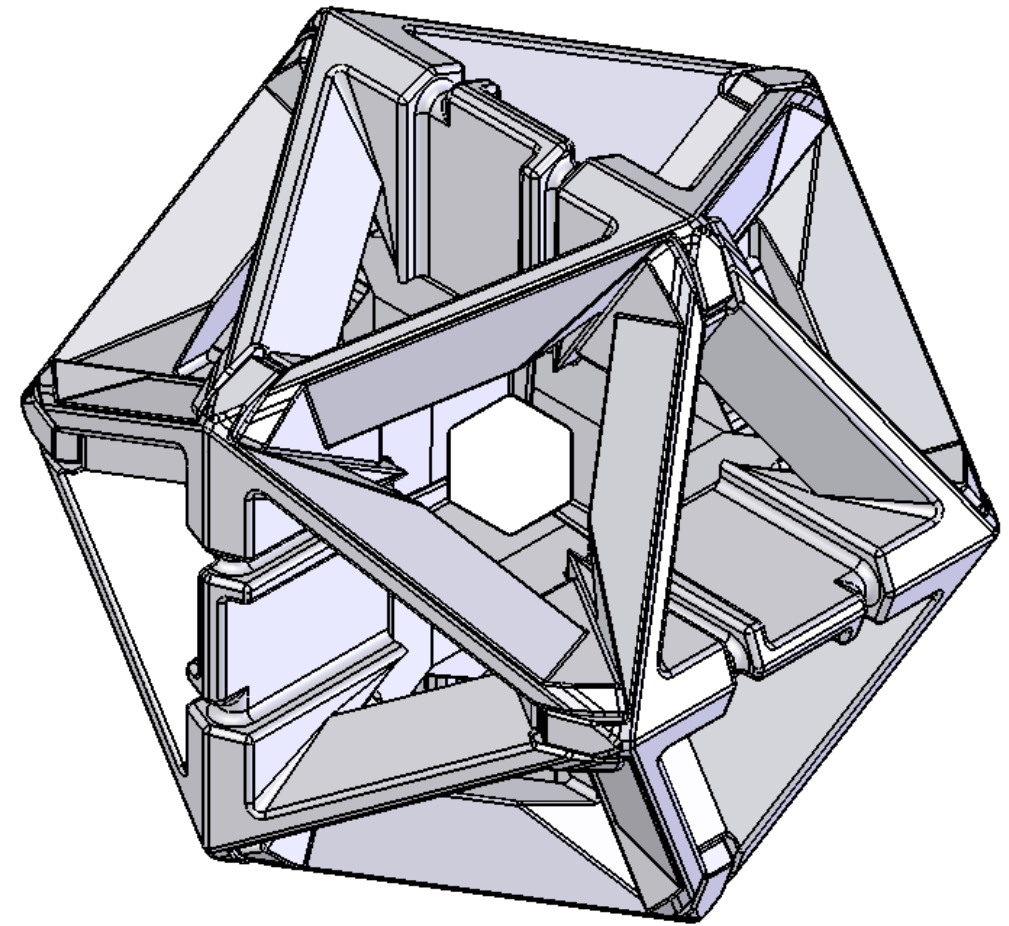
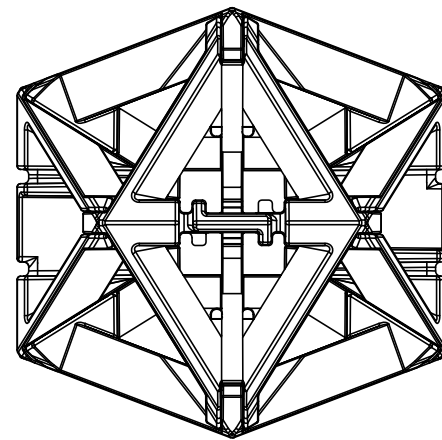
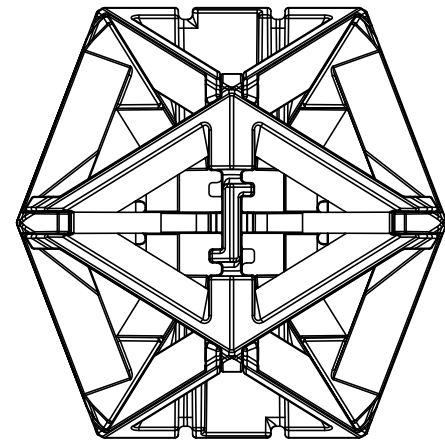
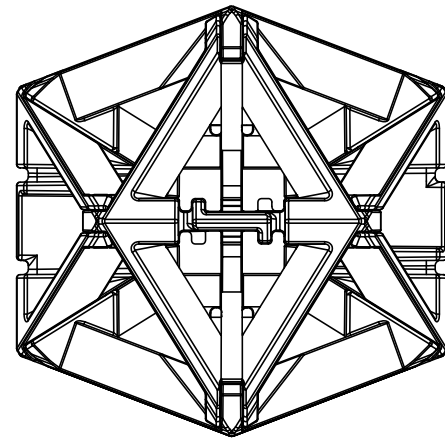

D

C

B

A

Note
This drawing shows views of a single ICA component.

PROPRIETARY AND CONFIDENTIAL
THE INFORMATION CONTAINED IN THIS DRAWING IS THE SOLE PROPERTY OF VGO, Inc. ANY REPRODUCTION IN PART OR AS A WHOLE WITHOUT THE WRITTEN PERMISSION OF VGO, Inc. IS PROHIBITED.

		UNLESS OTHERWISE SPECIFIED:	NAME	DATE	 10220 SW Nimbus, STE K/10, Portland, OR (503)968-6391 Individual Solid Element Flextegrity		
		DIMENSIONS ARE IN INCHES	DRAWN	DMV			2-18-08
		TOLERANCES:	CHECKED				
		FRACTIONAL $\pm 1/16"$	ENG APPR.				
		ANGULAR: MACH ± 1 BEND ± 1	MFG APPR.			TITLE:	
		TWO PLACE DECIMAL ± 0.010	Q.A.			SIZE	
		THREE PLACE DECIMAL ± 0.002	COMMENTS:			DWG. NO.	
		INTERPRET GEOMETRIC TOLERANCING PER:				REV	
		MATERIAL				-	
NEXT ASSY	USED ON	FINISH				SCALE: 1:1	
APPLICATION		DO NOT SCALE DRAWING				WEIGHT:	
						SHEET 3 OF 9	

8

7

6

5

4

3

2

1

8

7

6

5

4

3

2

1

D

C

B

A

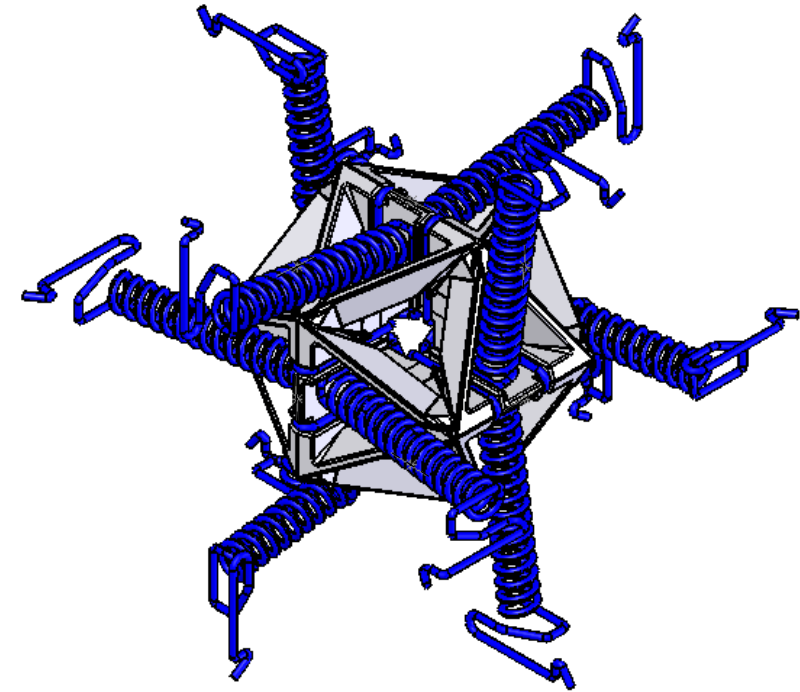
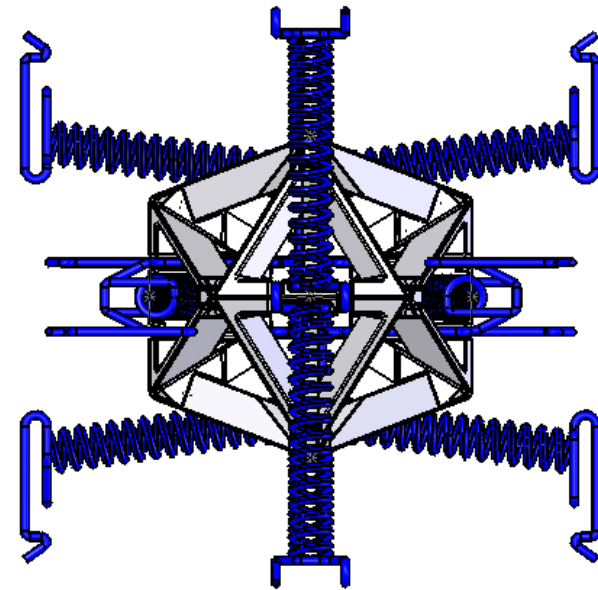
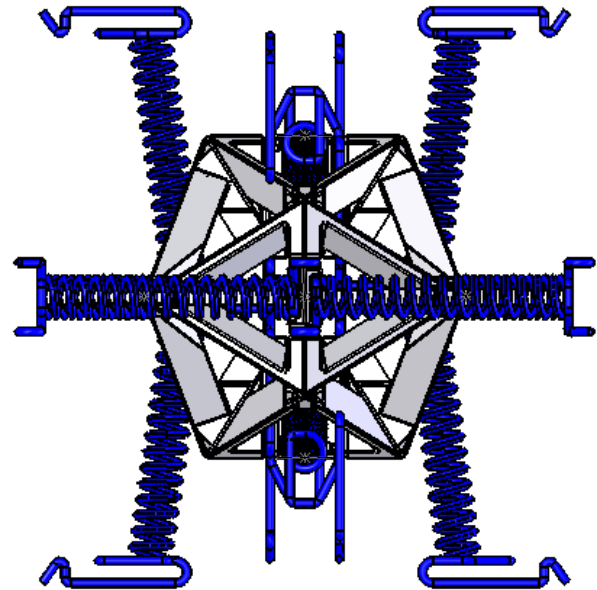
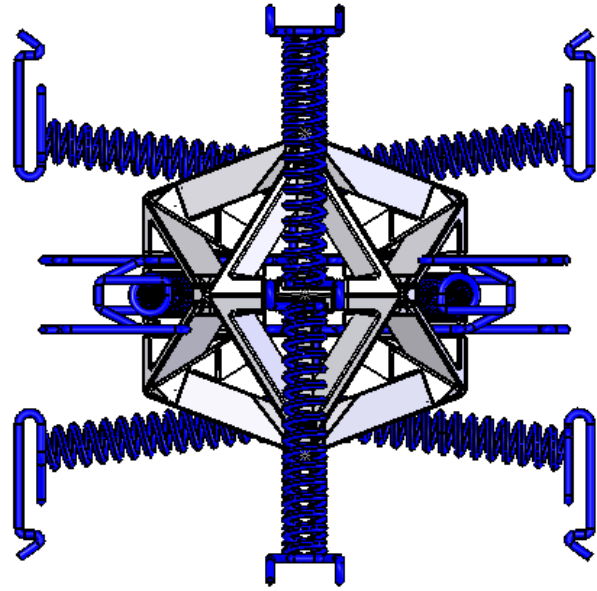

D

C

B

A

Note
This drawing shows views of a single ICA component with attached springs.

PROPRIETARY AND CONFIDENTIAL
THE INFORMATION CONTAINED IN THIS DRAWING IS THE SOLE PROPERTY OF VGO, Inc. ANY REPRODUCTION IN PART OR AS A WHOLE WITHOUT THE WRITTEN PERMISSION OF VGO, Inc. IS PROHIBITED.

		UNLESS OTHERWISE SPECIFIED:	NAME	DATE	 10220 SW Nimbus, STE K/10, Portland, OR (503)968-6391 Unit Representation Flextegrity	
		DIMENSIONS ARE IN INCHES	DRAWN	DMV		2-18-08
		TOLERANCES: FRACTIONAL $\pm 1/16"$	CHECKED			
		ANGULAR: MACH ± 1 BEND ± 1	ENG APPR.			
		TWO PLACE DECIMAL ± 0.010	MFG APPR.			
		THREE PLACE DECIMAL ± 0.002	Q.A.			
		INTERPRET GEOMETRIC TOLERANCING PER:	COMMENTS:			
		MATERIAL				
NEXT ASSY	USED ON	FINISH				
APPLICATION		DO NOT SCALE DRAWING				
			SIZE	DWG. NO.	REV	
			B	07093-500	-	
			SCALE: 1:1.3938	SHEET:	SHEET 4 OF 9	

8

7

6

5

4

3

2

1

8

7

6

5

4

3

2

1

D

C

B

A

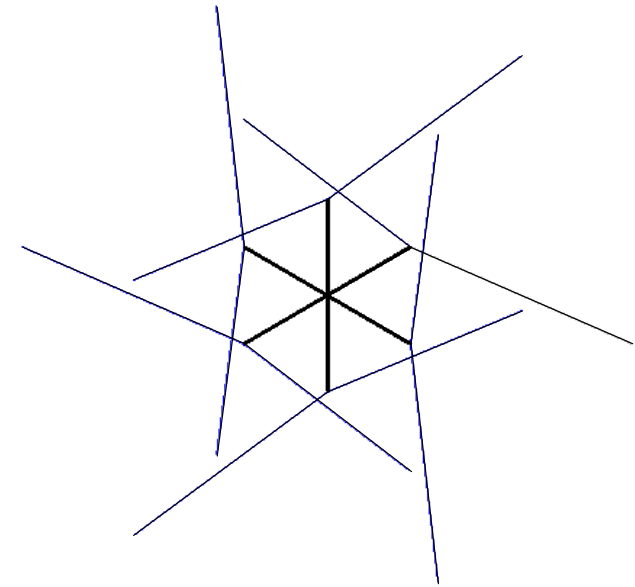
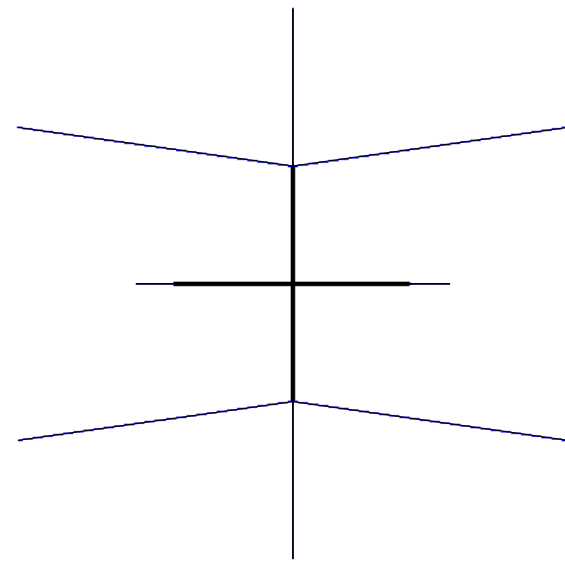
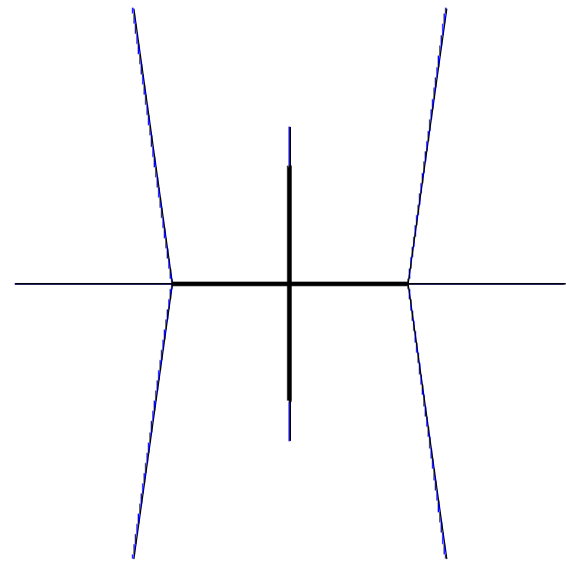
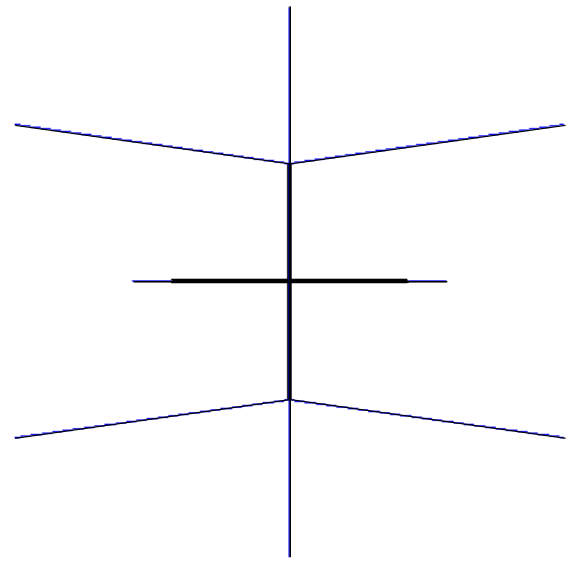

D

C

B

A

Note
 This drawing shows views of the FEA model elements for a single ICA component with springs attached. The black lines indicate rigid connectors, the blue lines indicate spring elements used to simulate the effect of the spring connectors.

PROPRIETARY AND CONFIDENTIAL
 THE INFORMATION CONTAINED IN THIS DRAWING IS THE SOLE PROPERTY OF VGO, Inc. ANY REPRODUCTION IN PART OR AS A WHOLE WITHOUT THE WRITTEN PERMISSION OF VGO, Inc. IS PROHIBITED.

		UNLESS OTHERWISE SPECIFIED:	NAME	DATE
		DIMENSIONS ARE IN INCHES	DRAWN	DMV
		TOLERANCES:	CHECKED	2-18-08
		FRACTIONAL $\pm 1/16"$	ENG APPR.	
		ANGULAR: MACH ± 1 BEND ± 1	MFG APPR.	
		TWO PLACE DECIMAL ± 0.010	Q.A.	
		THREE PLACE DECIMAL ± 0.002	COMMENTS:	
		INTERPRET GEOMETRIC TOLERANCING PER:		
		MATERIAL		
NEXT ASSY	USED ON	FINISH		
APPLICATION		DO NOT SCALE DRAWING		

VGO Testing & Inspection Engineers
 10220 SW Nimbus, STE K/10, Portland, OR (503)968-6391

TITLE:
Stick Representation
 Flextegrity

SIZE	DWG. NO.	REV
B	07093-500	-

SCALE: 1:1.3938 SHEET: 5 OF 9

8

7

6

5

4

3

2

1

8 7 6 5 4 3 2 1

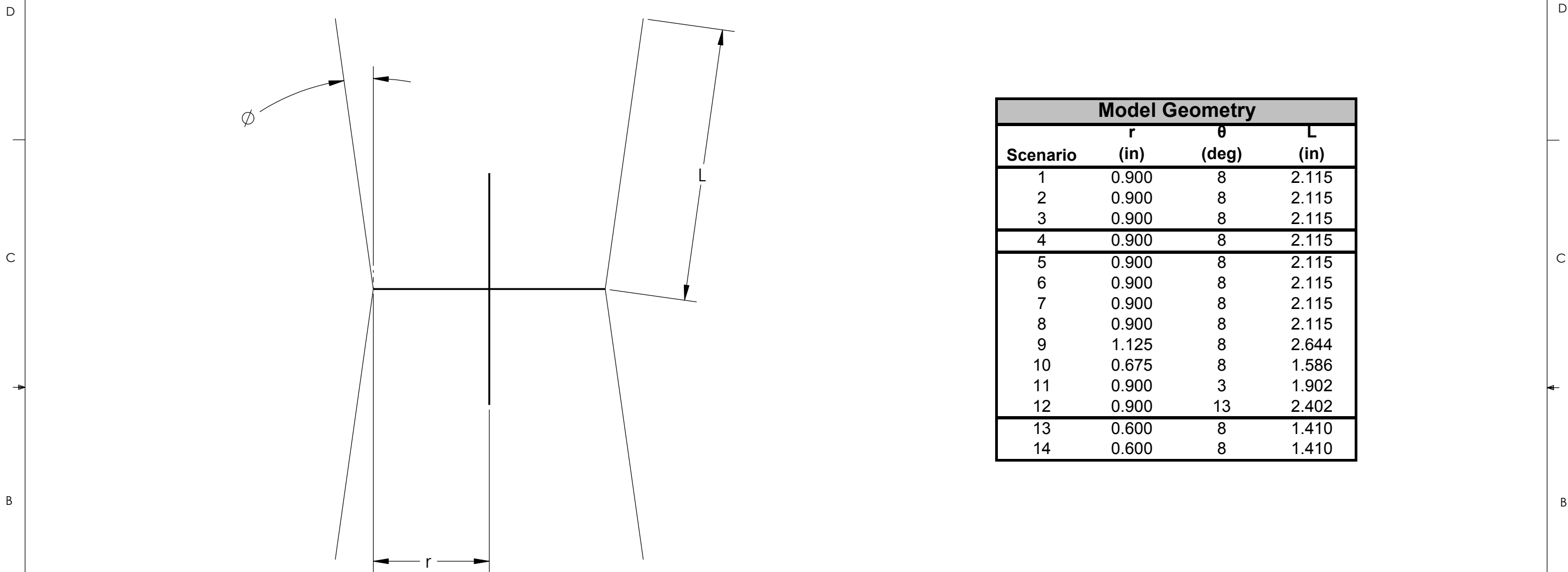

Model Geometry			
Scenario	r (in)	θ (deg)	L (in)
1	0.900	8	2.115
2	0.900	8	2.115
3	0.900	8	2.115
4	0.900	8	2.115
5	0.900	8	2.115
6	0.900	8	2.115
7	0.900	8	2.115
8	0.900	8	2.115
9	1.125	8	2.644
10	0.675	8	1.586
11	0.900	3	1.902
12	0.900	13	2.402
13	0.600	8	1.410
14	0.600	8	1.410

Note
 This drawing shows views of the FEA model elements for a single ICA component with springs attached. The thick lines indicate rigid connectors, the thin lines indicate spring elements used to simulate the effect of the spring connectors.

PROPRIETARY AND CONFIDENTIAL
 THE INFORMATION CONTAINED IN THIS DRAWING IS THE SOLE PROPERTY OF VGO, Inc. ANY REPRODUCTION IN PART OR AS A WHOLE WITHOUT THE WRITTEN PERMISSION OF VGO, Inc. IS PROHIBITED.

		UNLESS OTHERWISE SPECIFIED:	NAME	DATE
		DIMENSIONS ARE IN INCHES	DRAWN	DMV
		TOLERANCES:	CHECKED	2-18-08
		FRACTIONAL ± 1/16"	ENG APPR.	
		ANGULAR: MACH ± 1 BEND ± 1	MFG APPR.	
		TWO PLACE DECIMAL ± 0.010	Q.A.	
		THREE PLACE DECIMAL ± 0.002	COMMENTS:	
		INTERPRET GEOMETRIC TOLERANCING PER:		
		MATERIAL		
		FINISH		
NEXT ASSY	USED ON			
APPLICATION	DO NOT SCALE DRAWING			

VGO Testing & Inspection Engineers
 10220 SW Nimbus, STE K/10, Portland, OR (503)968-6391

TITLE:
Element Dimensions
 Flextegrity

SIZE	DWG. NO.	REV
B	07093-500	-
SCALE: 4:3	WEIGHT:	SHEET 6 OF 9

A

A

8 7 6 5 4 3 2 1

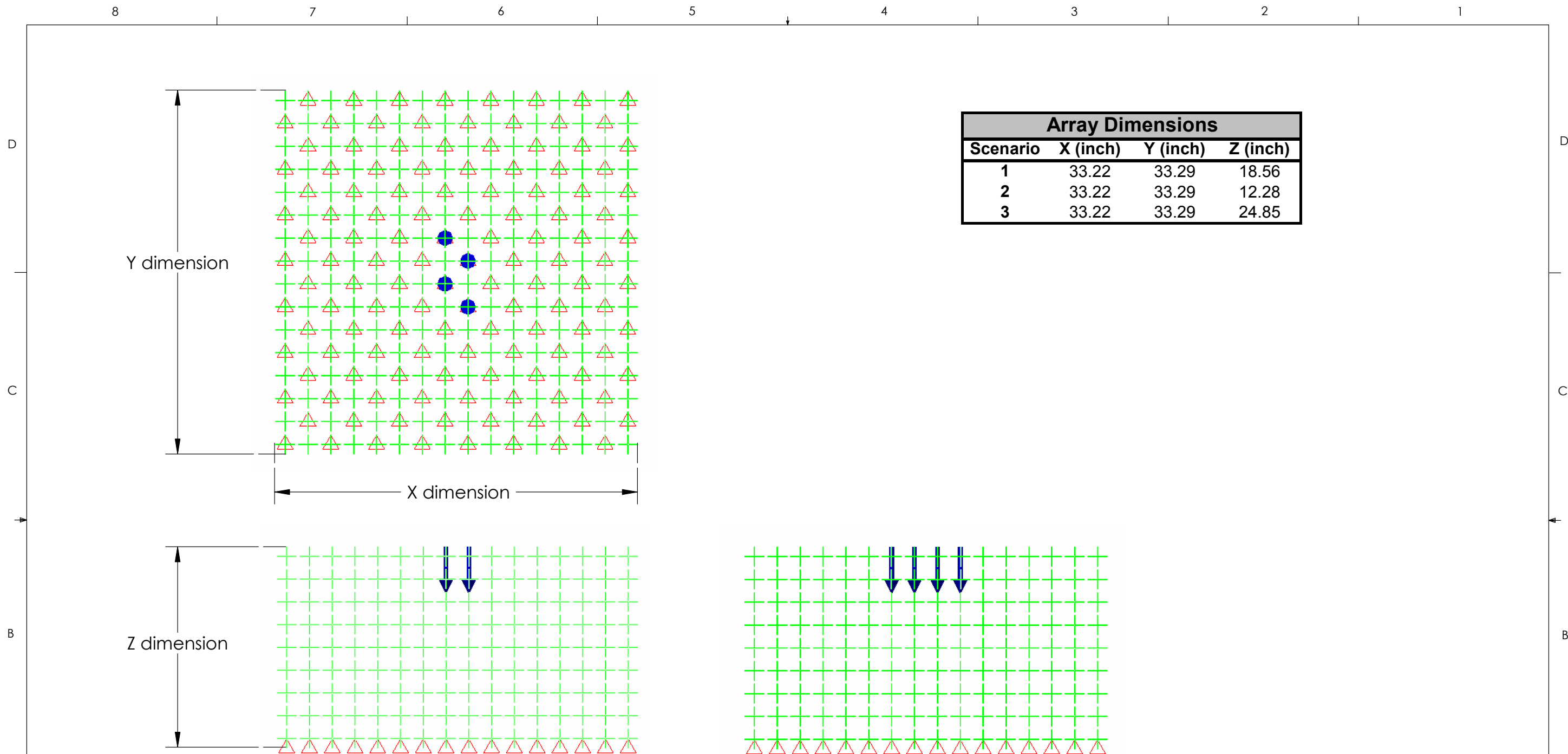

Array Dimensions			
Scenario	X (inch)	Y (inch)	Z (inch)
1	33.22	33.29	18.56
2	33.22	33.29	12.28
3	33.22	33.29	24.85

Note
 This drawing shows the configuration of the rigid elements used in Scenarios 1-3 of the FEA models. The bottom nodes of the bottom elements are restrained. Loading is applied though all of the top surface nodes of a 2x2 array of solid elements.

PROPRIETARY AND CONFIDENTIAL
 THE INFORMATION CONTAINED IN THIS DRAWING IS THE SOLE PROPERTY OF VGO, Inc. ANY REPRODUCTION IN PART OR AS A WHOLE WITHOUT THE WRITTEN PERMISSION OF VGO, Inc. IS PROHIBITED.

UNLESS OTHERWISE SPECIFIED:		NAME	DATE
DIMENSIONS ARE IN INCHES		DRAWN	DMV
TOLERANCES:		CHECKED	
FRACTIONAL ± 1/16"		ENG APPR.	
ANGULAR: MACH ± 1 BEND ± 1		MFG APPR.	
TWO PLACE DECIMAL ±0.010		Q.A.	
THREE PLACE DECIMAL ±0.002		COMMENTS:	
INTERPRET GEOMETRIC TOLERANCING PER:			
MATERIAL			
FINISH			
NEXT ASSY	USED ON		
APPLICATION	DO NOT SCALE DRAWING		

VGO Testing & Inspection Engineers
 10220 SW Nimbus, STE K/10, Portland, OR (503)968-6391

TITLE:
Square Weave
 Flextegrity

SIZE	DWG. NO.	REV
B	07093-500	-

SCALE: 1:1 | WEIGHT: | SHEET 7 OF 9

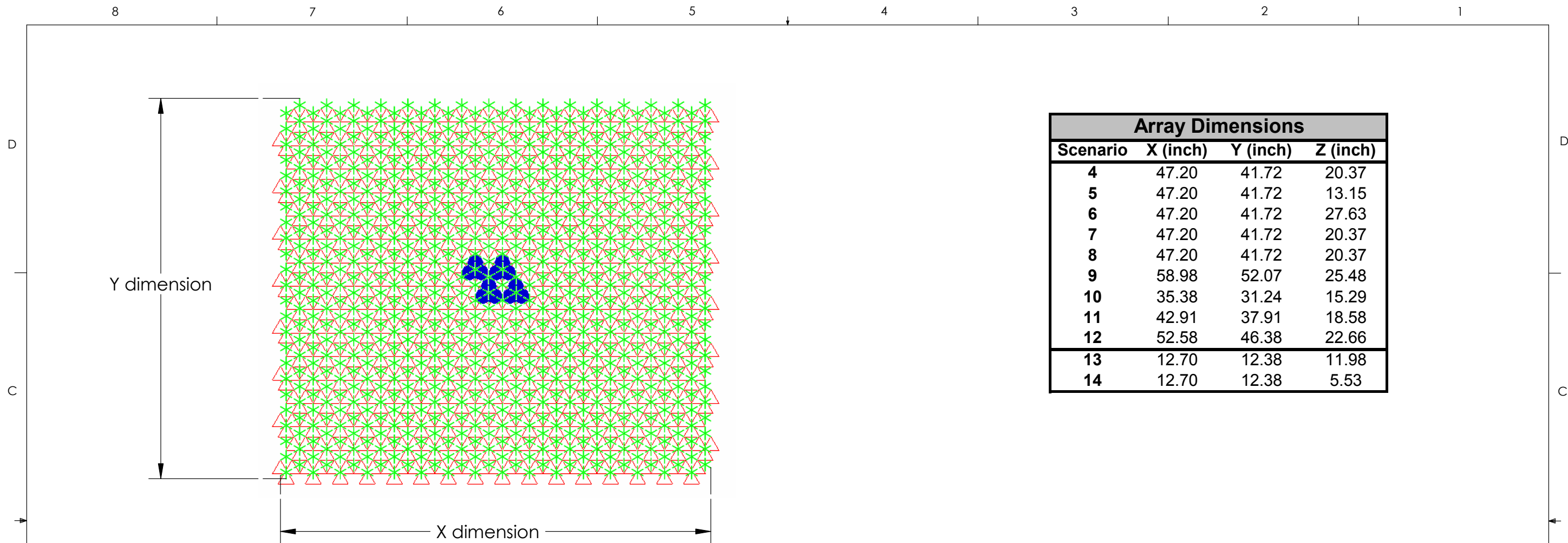

Array Dimensions			
Scenario	X (inch)	Y (inch)	Z (inch)
4	47.20	41.72	20.37
5	47.20	41.72	13.15
6	47.20	41.72	27.63
7	47.20	41.72	20.37
8	47.20	41.72	20.37
9	58.98	52.07	25.48
10	35.38	31.24	15.29
11	42.91	37.91	18.58
12	52.58	46.38	22.66
13	12.70	12.38	11.98
14	12.70	12.38	5.53

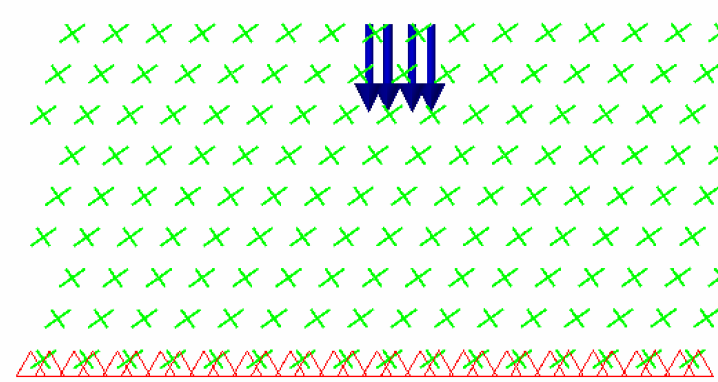
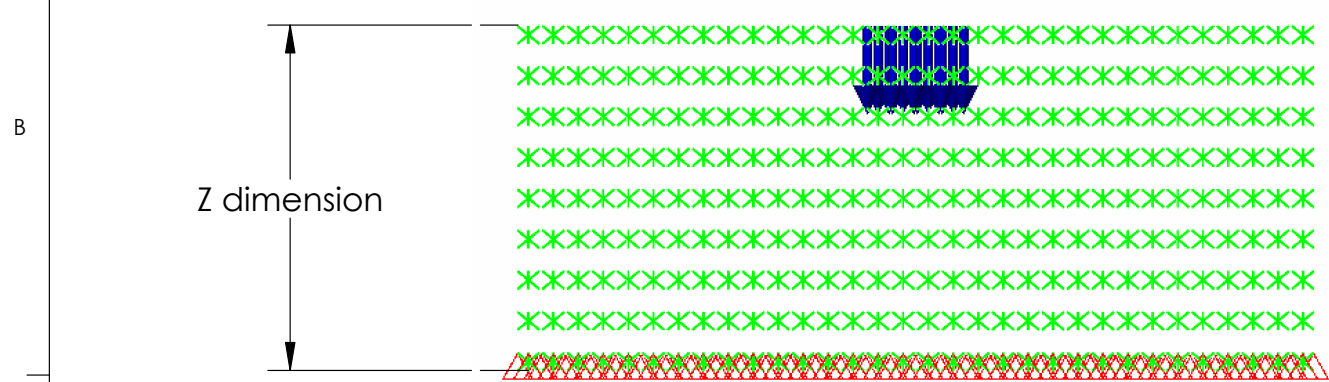

Note
 This drawing shows the configuration of the rigid elements used in Scenarios 4-12 of the FEA models. The bottom nodes of the bottom elements are restrained. Loading is applied though all of the top surface nodes of a 2x2 array of solid elements.

PROPRIETARY AND CONFIDENTIAL
 THE INFORMATION CONTAINED IN THIS DRAWING IS THE SOLE PROPERTY OF VGO, Inc. ANY REPRODUCTION IN PART OR AS A WHOLE WITHOUT THE WRITTEN PERMISSION OF VGO, Inc. IS PROHIBITED.

		UNLESS OTHERWISE SPECIFIED:		NAME	DATE	 10220 SW Nimbus, STE K/10, Portland, OR (503)968-6391 Bias Weave Flextegrity	
		DIMENSIONS ARE IN INCHES		DRAWN	DMV		2-18-08
		TOLERANCES:		CHECKED			
		FRACTIONAL ± 1/16"		ENG APPR.			
		ANGULAR: MACH ± 1		MFG APPR.			
		TWO PLACE DECIMAL ±0.010		Q.A.			
		THREE PLACE DECIMAL ±0.002		COMMENTS:			
		INTERPRET GEOMETRIC TOLERANCING PER:					
		MATERIAL				SIZE B	
		FINISH				DWG. NO. 07093-500	
NEXT ASSY	USED ON					REV -	
APPLICATION		DO NOT SCALE DRAWING				SCALE: 1:1	
						WEIGHT:	
						SHEET 8 OF 9	

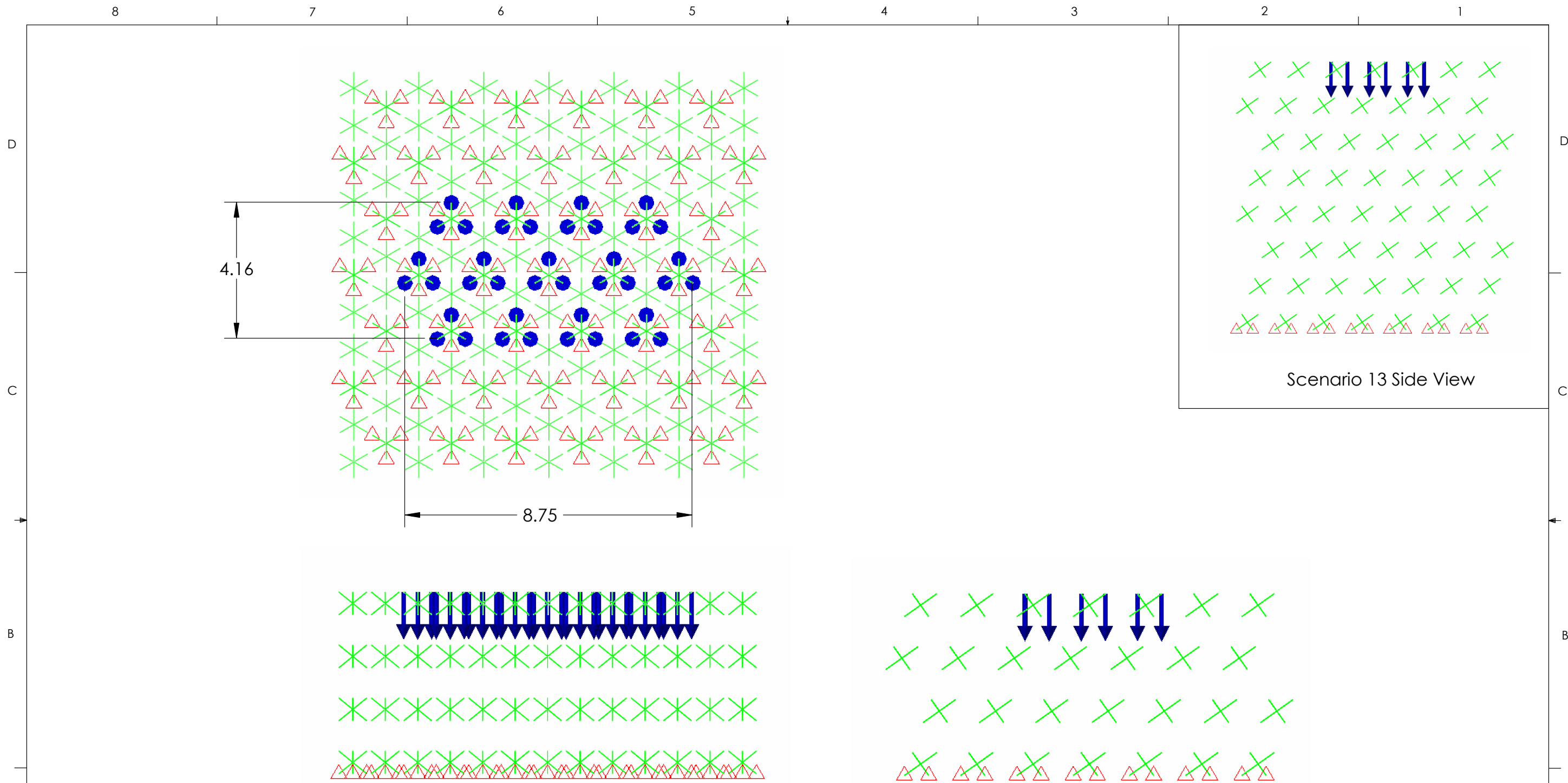

Scenario 13 Side View

Note
 This drawing shows the configuration of the rigid elements used in Scenarios 13-14 of the FEA models (Scenario 14 shown). The bottom nodes of the bottom elements are restrained. Loading is applied through an array of top surface nodes as shown.

PROPRIETARY AND CONFIDENTIAL
 THE INFORMATION CONTAINED IN THIS DRAWING IS THE SOLE PROPERTY OF VGO, Inc. ANY REPRODUCTION IN PART OR AS A WHOLE WITHOUT THE WRITTEN PERMISSION OF VGO, Inc. IS PROHIBITED.

		UNLESS OTHERWISE SPECIFIED:		NAME	DATE
		DIMENSIONS ARE IN INCHES		DRAWN	DMV 2-18-08
		TOLERANCES:		CHECKED	
		FRACTIONAL ± 1/16"		ENG APPR.	
		ANGULAR: MACH ± 1 BEND ± 1		MFG APPR.	
		TWO PLACE DECIMAL ±0.010		Q.A.	
		THREE PLACE DECIMAL ±0.002		COMMENTS:	
		INTERPRET GEOMETRIC TOLERANCING PER:			
		MATERIAL			
		FINISH			
NEXT ASSY	USED ON				
APPLICATION		DO NOT SCALE DRAWING			

VGO Testing & Inspection Engineers
 10220 SW Nimbus, STE K/10, Portland, OR (503)968-6391

TITLE:
Scenario 13-14
 Flextegrity

SIZE	DWG. NO.	REV
B	07093-500	-
SCALE: 1:1	WEIGHT:	SHEET 9 OF 9

Appendix B

Scenario 1-12 Results

07093 - FEA Scenarios 1-12									
Study	Scenario	Array Type	Footprint (IC's)	Height (IC's)	axial K (lbf/in)	r (in)	θ (deg)	L (in)	Deflection (in)
Square Weave Height	1	Square	16x16	9	23.4	0.900	8	2.115	2.94
	2	Square	16x16	6	23.4	0.900	8	2.115	2.62
	3	Square	16x16	12	23.4	0.900	8	2.115	3.10
Bias-Weave Height	4	Bias-Weave	16x16	9	23.4	0.900	8	2.115	3.39
	5	Bias-Weave	16x16	6	23.4	0.900	8	2.115	3.13
	6	Bias-Weave	16x16	12	23.4	0.900	8	2.115	3.56
Bias-Weave Stiffness	7	Bias-Weave	16x16	9	29.1	0.900	8	2.115	3.00
	8	Bias-Weave	16x16	9	17.5	0.900	8	2.115	3.98
Bias Weave Radius	9	Bias-Weave	16x16	9	23.4	1.125	8	2.644	4.59
	10	Bias-Weave	16x16	9	23.4	0.675	8	1.586	2.28
Bias Weave Angle	11	Bias-Weave	16x16	9	23.4	0.900	3	1.902	3.13
	12	Bias-Weave	16x16	9	23.4	0.900	13	2.402	3.70

- 1) All scenarios used a spring I-factor of $8.47e-8 \text{ in}^4$, which corresponds to a bending stiffness of 0.8 lbf/in for a length of 2.115 inches.
- 2) All scenarios used a spring J-factor of $1.98e-7 \text{ in}^4$, which corresponds to a torsional stiffness of $1.88e-2 \text{ (in-lb/deg)}$ for a length of 2.115 inches.
- 3) Scenario 4 is the base reference case used for sensitivity studies
- 4) Loading was 200 lbf distributed over the center 4 elements. For the square array, this was 4x50lbf, for the bias weave, this was 12x16.6lbf
- 5) L was the swing variable as it is a function of r and θ . [$L = -2*r / (\sin \theta - \cos \theta)$]

07093 - ICA Stiffness

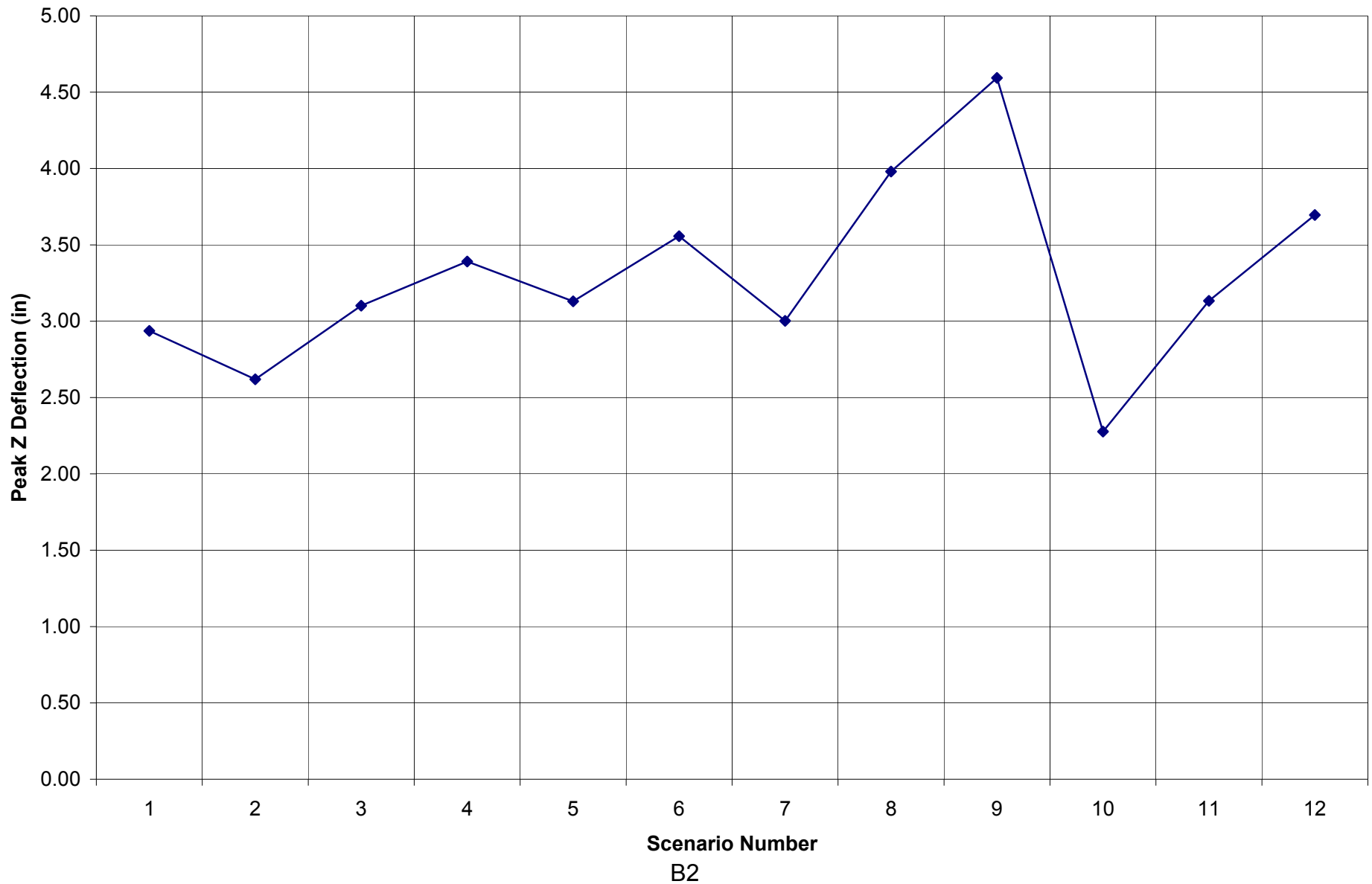

07093 - Array Height Effect
(Scenarios 1-3 and 4-6)

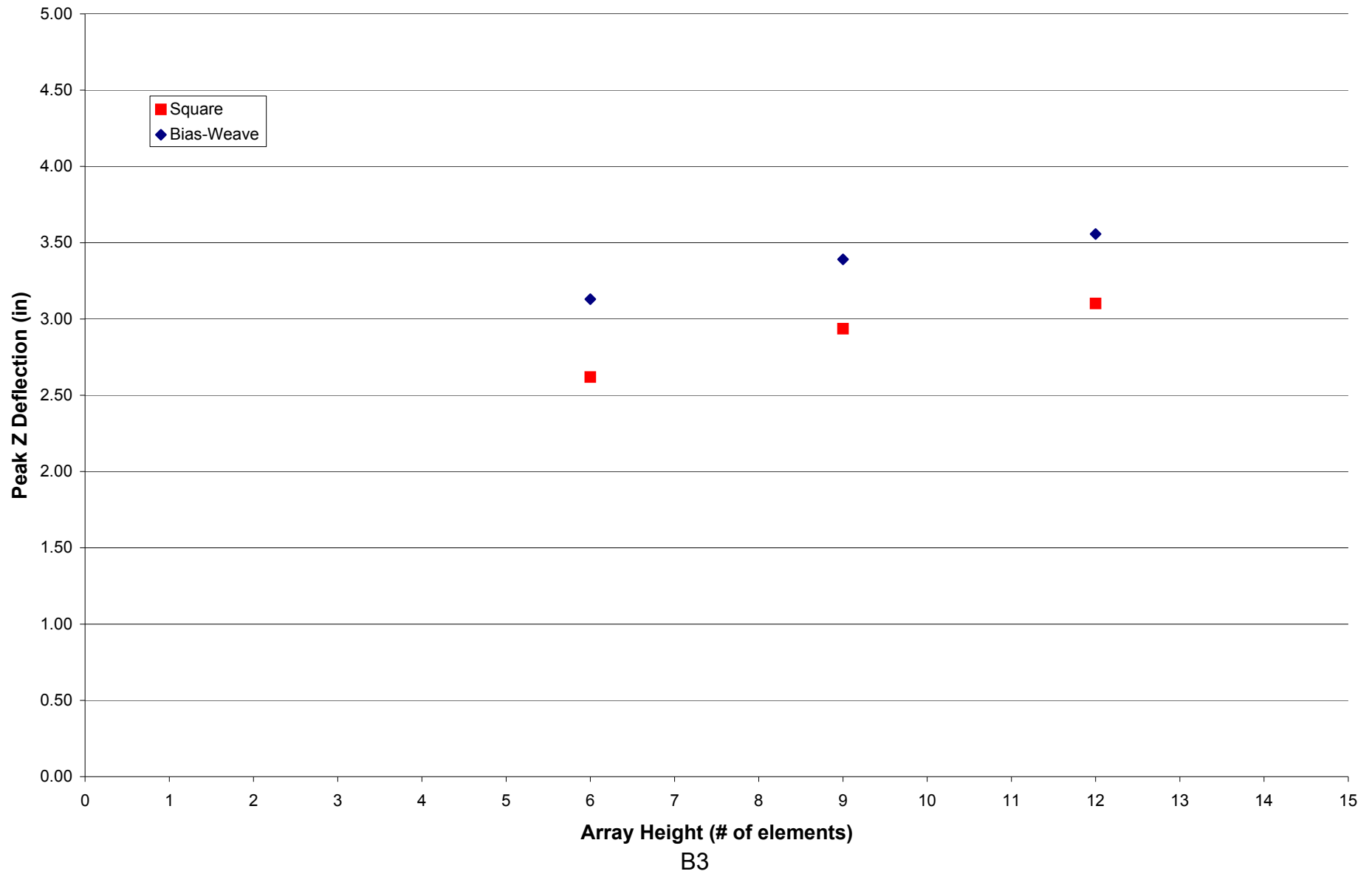

Spring Axial Stiffness Effect
(Scenarios 4, 7 and 8)

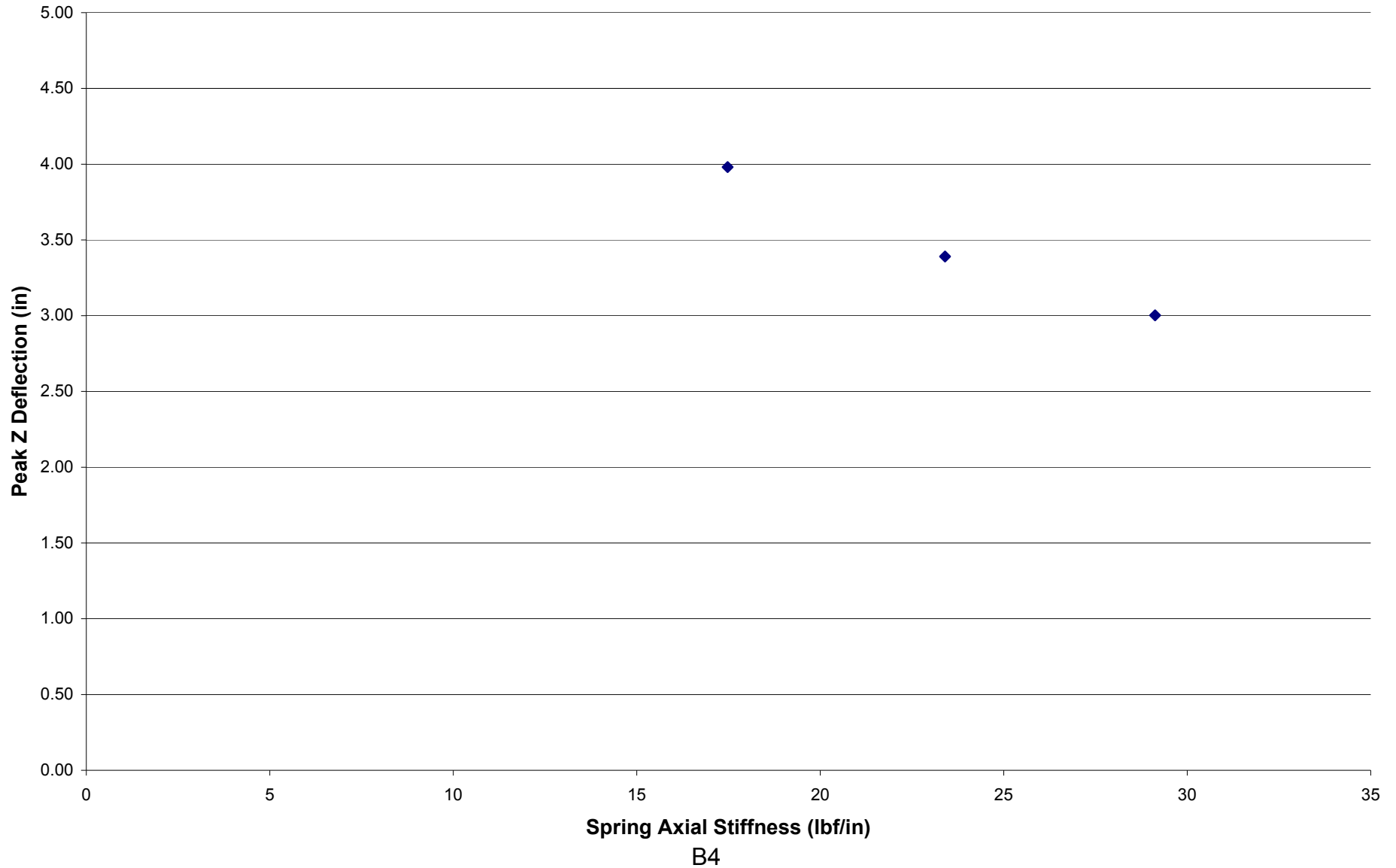

07093 - Rigid Element Radius Effect
(Scenarios 4, 9 and 10)

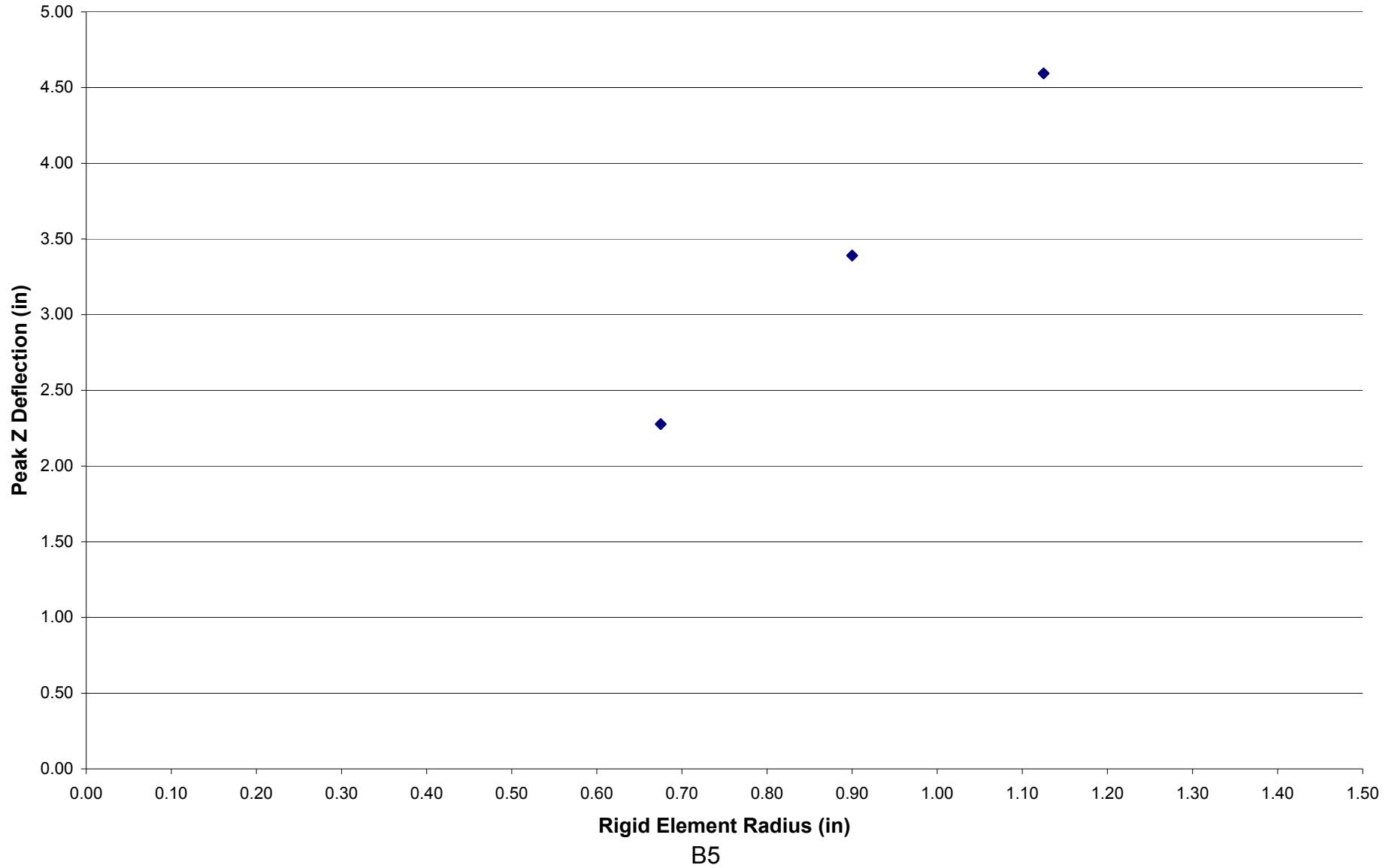

07093 - Spring Angle Effect
(Scenarios 4, 11 and 12)

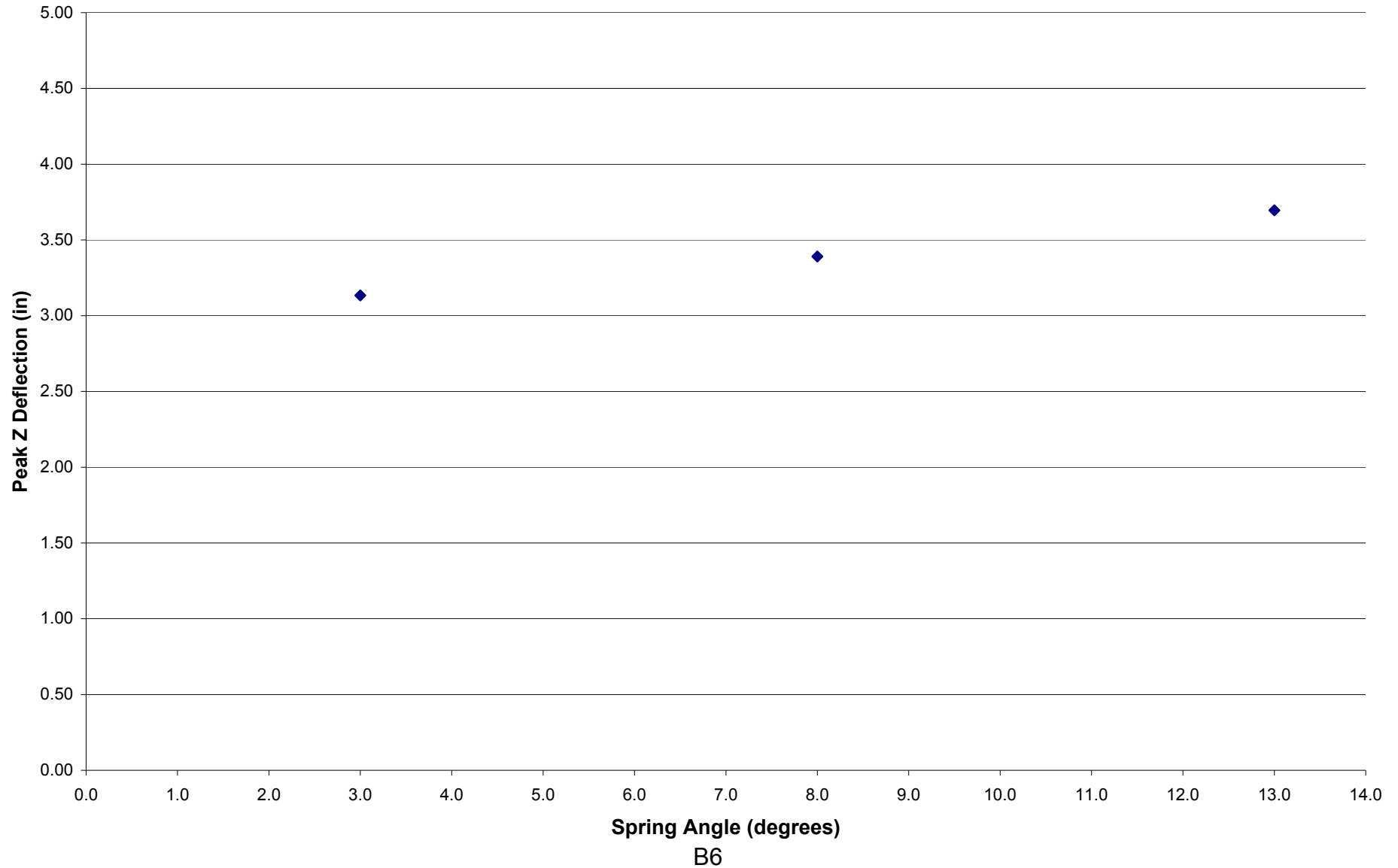

Appendix C

Scenario 13-14 Results

07093 - FEA Scenarios 13-14										
Study	Scenario	Stiffness Multiplier	Height (IC's)	Axial K (lbf/in)	Torsional K (in-lb/deg)	Bending K (lbf/in)	A (in ²)	J (in ⁴)	I (in ⁴)	Deflection (in)
2500 lbf thick	13	1x	8	35.1	0.03	2.7	1.65E-06	1.98E-07	8.47E-08	13.09
		20x	8	702.1	0.57	54.4	3.30E-05	3.96E-06	1.69E-06	0.65
		25x	8	877.7	0.71	68.0	4.13E-05	4.95E-06	2.12E-06	0.52
		30x	8	1053.2	0.85	81.6	4.95E-05	5.94E-06	2.54E-06	0.44
2500 lbf thin	14	1x	4	35.1	0.03	2.7	1.65E-06	1.98E-07	8.47E-08	7.87
		20x	4	702.1	0.57	54.4	3.30E-05	3.96E-06	1.69E-06	0.39

1) All scenarios used $r = 0.600$ inch, $\theta = 8$ degrees, and $L = 1.410$ inch.

2) Loading was 2500 lbf distributed over the center 13 elements.

07093 Scenario 13 & 14 Results

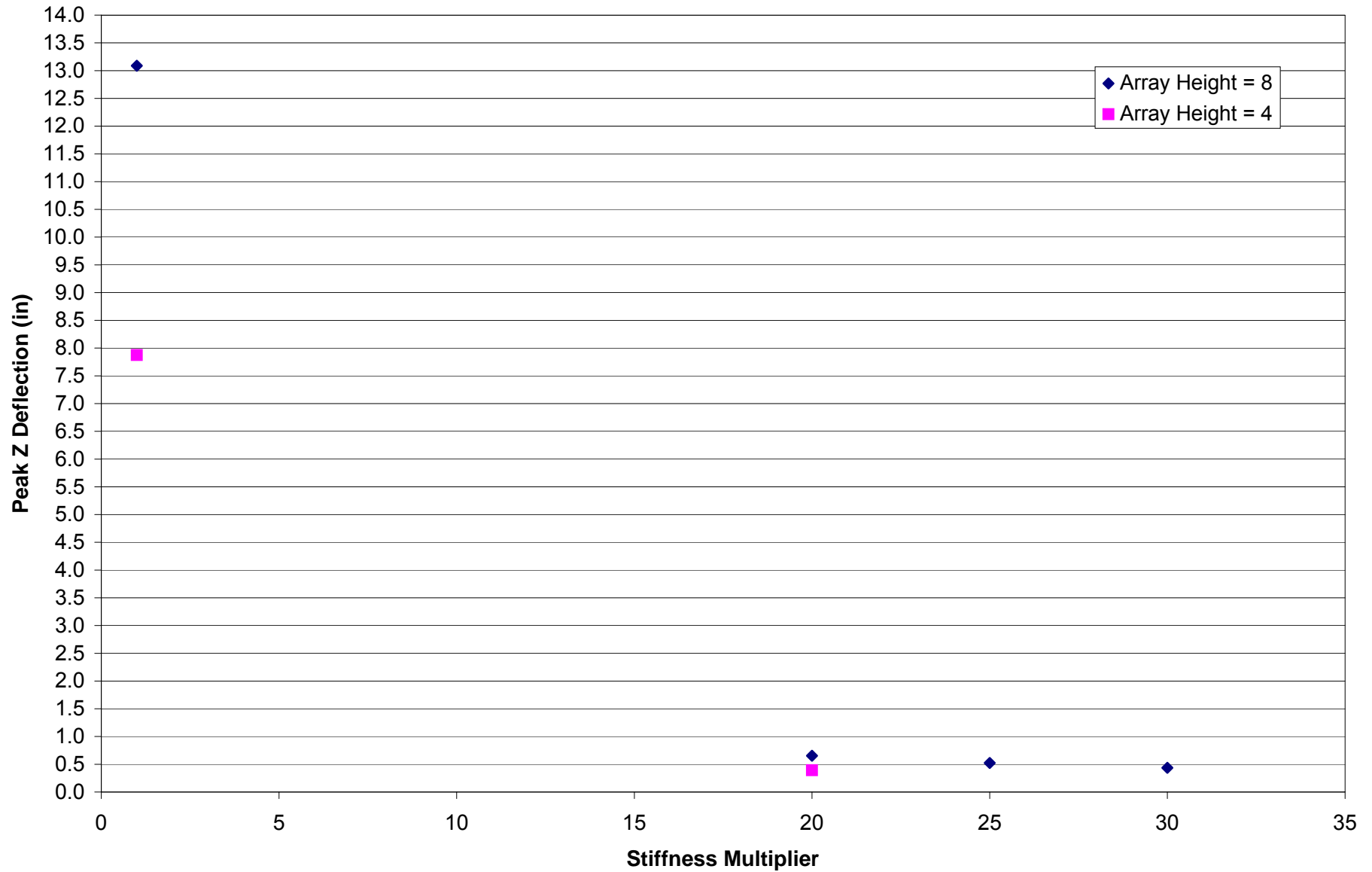

Appendix D

Select Graphical Results

07093 Scenario 1 - Front

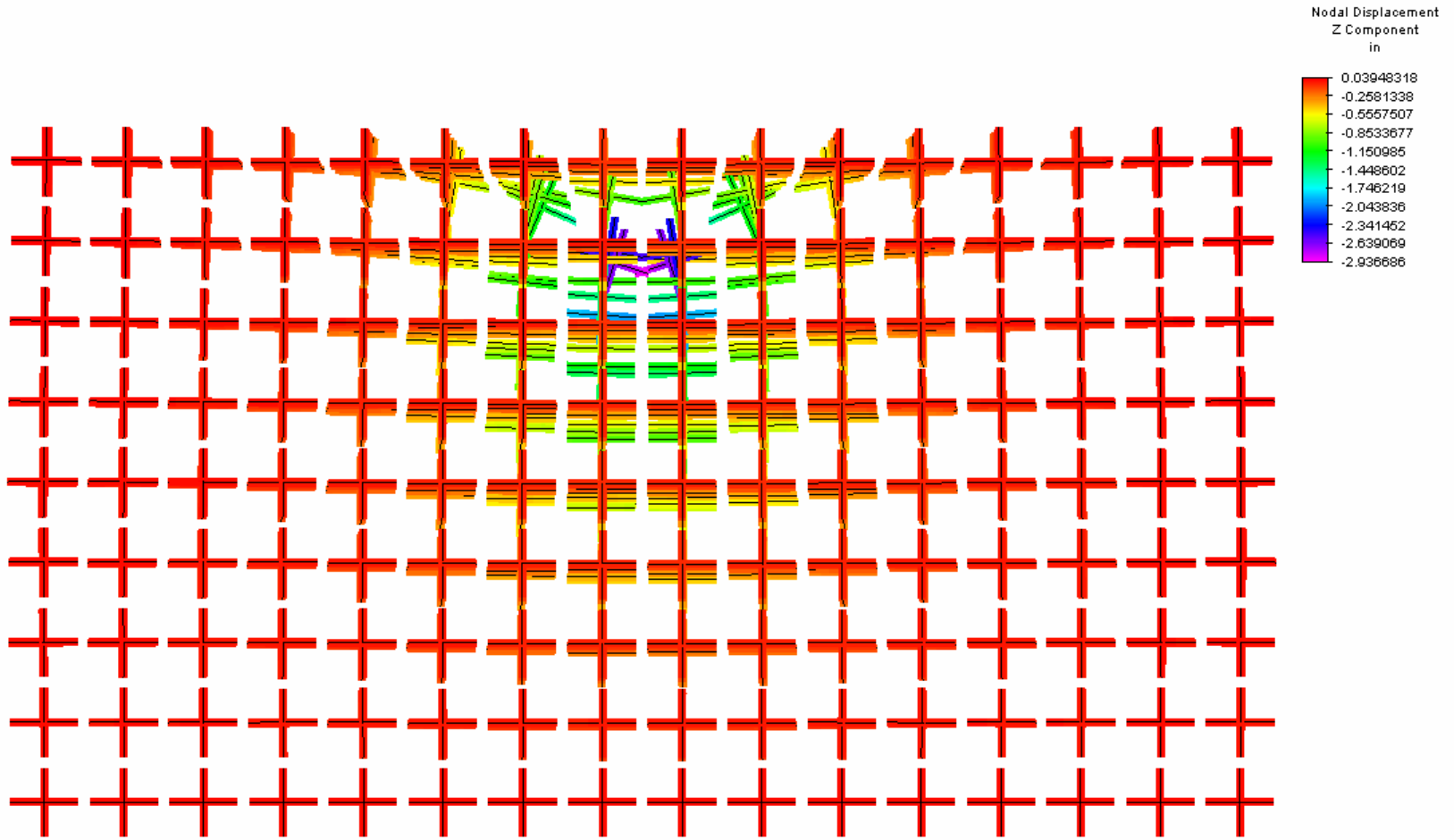

Load Case: 1 of 1

Maximum Value: 0.0394832 in

Minimum Value: -2.93669 in

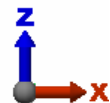
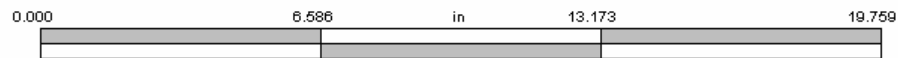

07093 Scenario 1 - Side

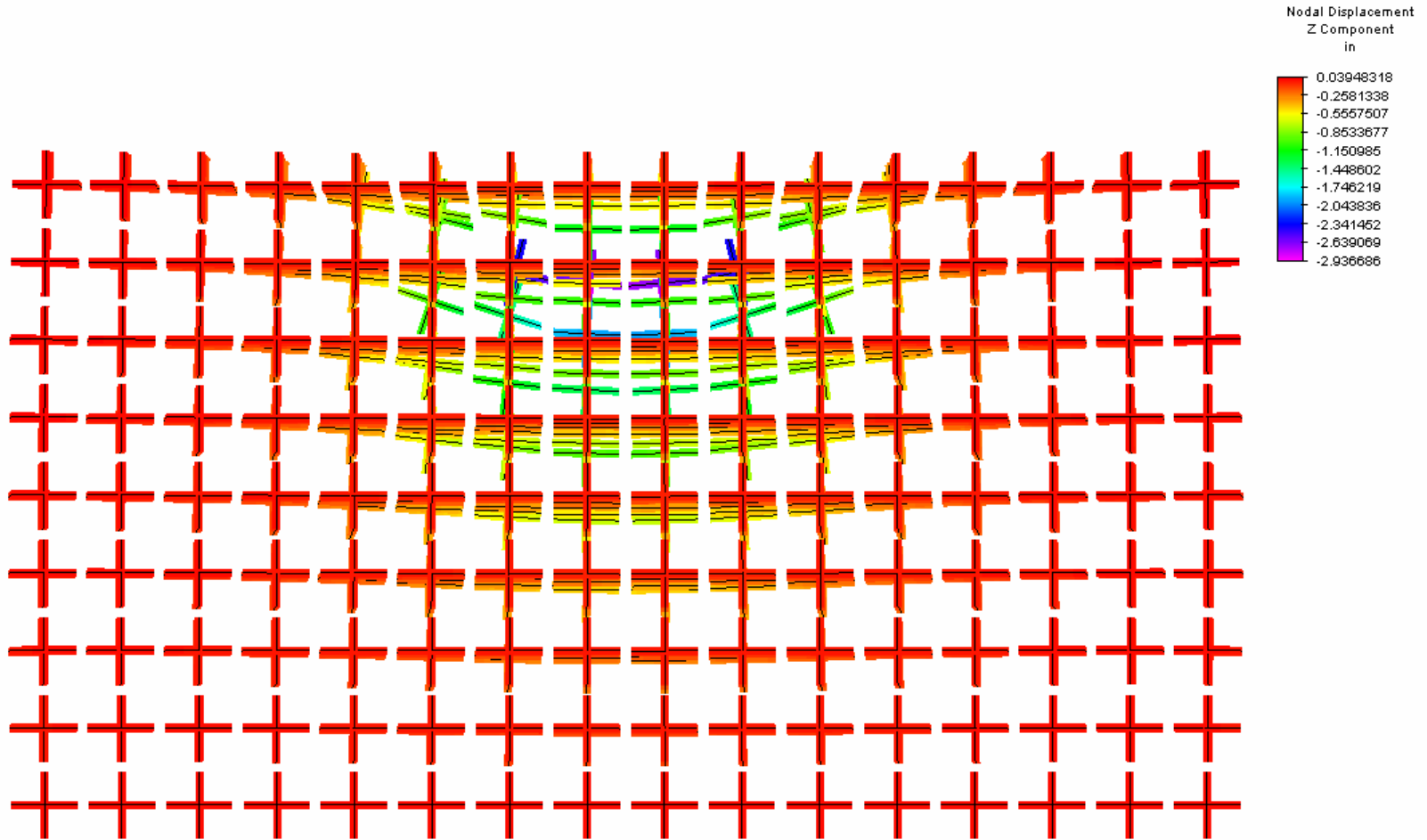

Load Case: 1 of 1

Maximum Value: 0.0394832 in

Minimum Value: -2.93669 in

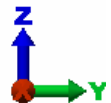
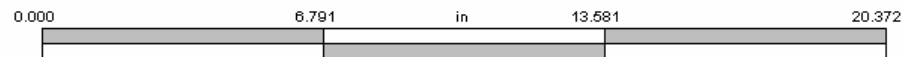

07093 Scenario 1 – Top

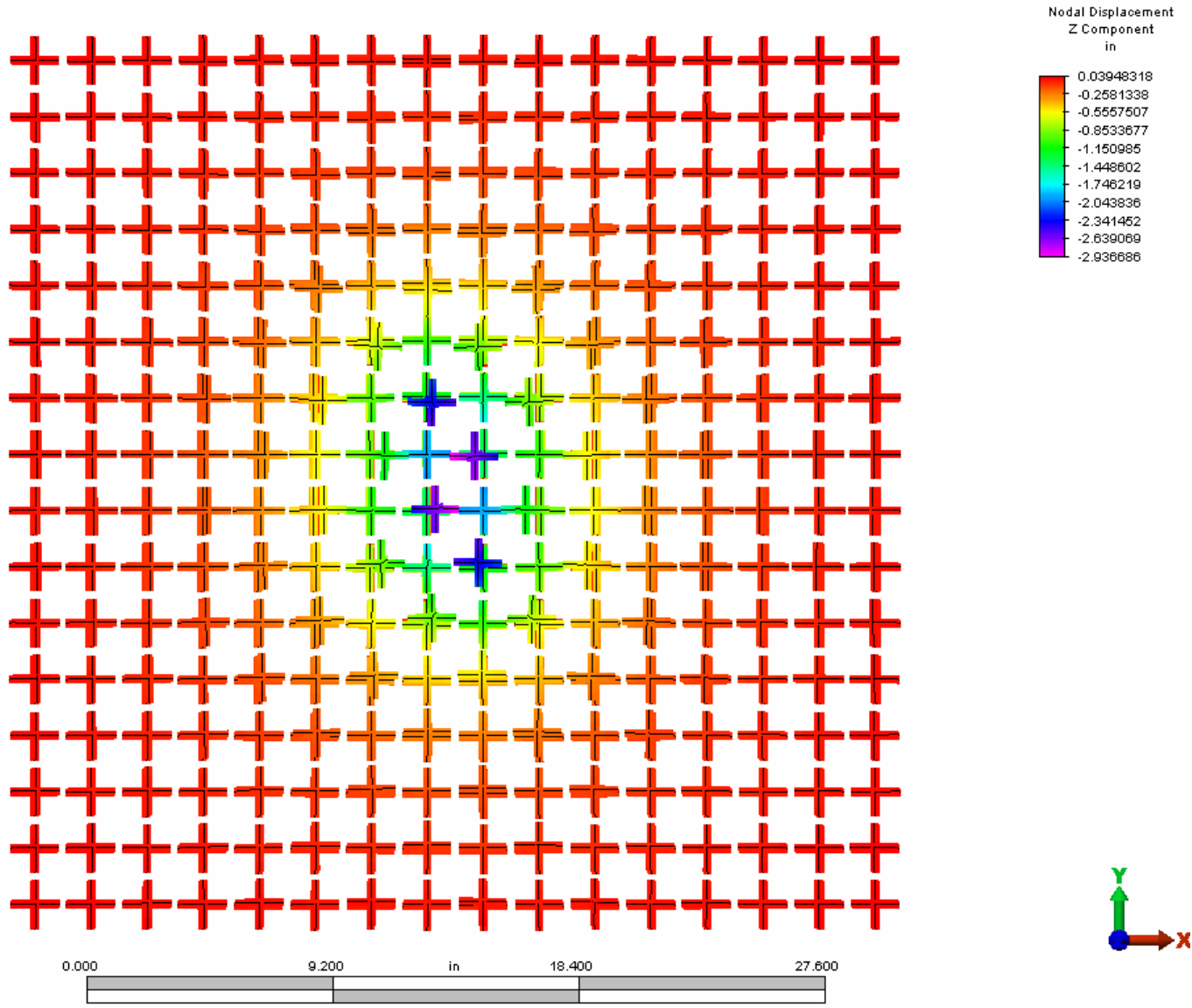

Load Case: 1 of 1
Maximum Value: 0.0394832 in
Minimum Value: -2.93669 in

07093 Scenario 4 - Front

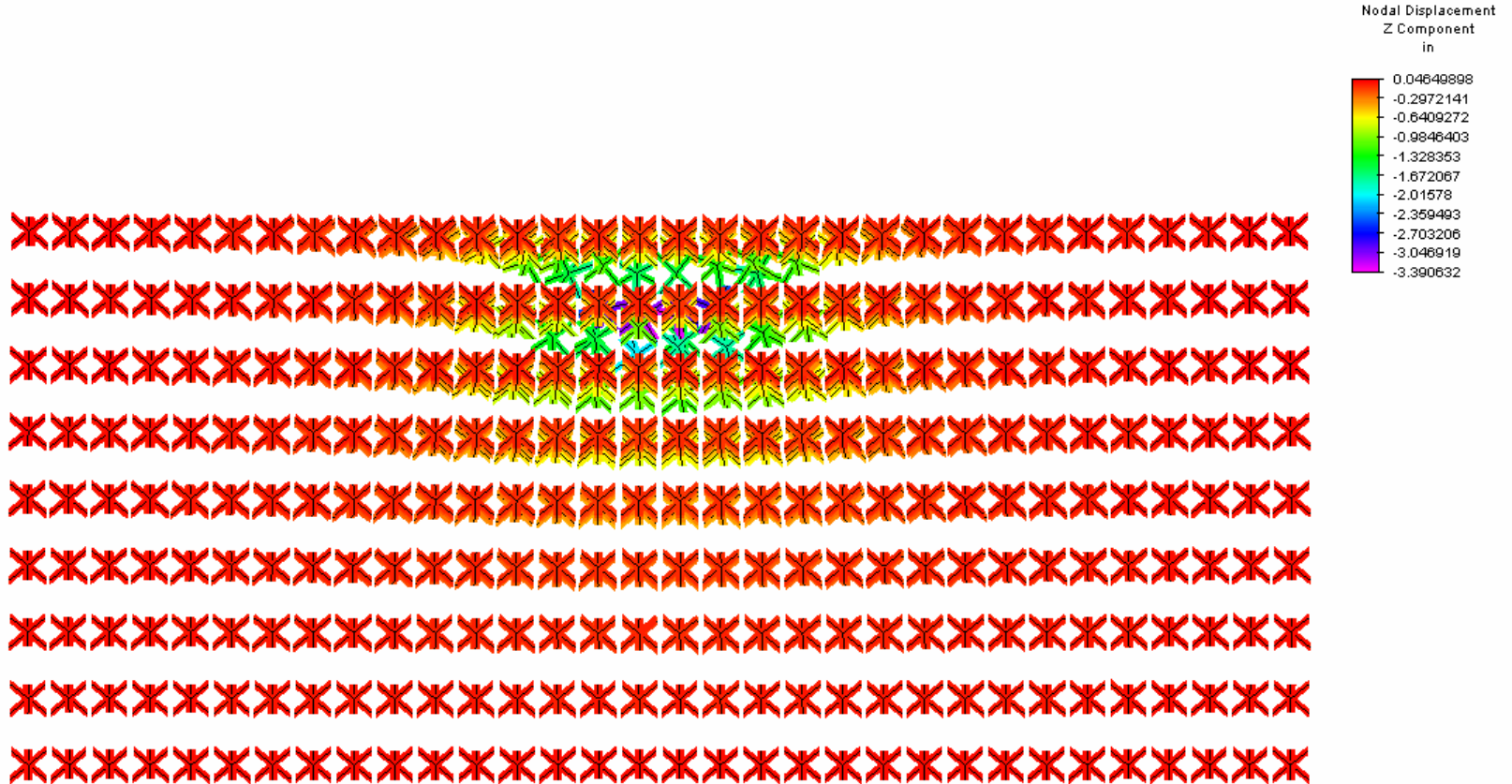

Load Case: 1 of 1

Maximum Value: 0.046499 in

Minimum Value: -3.39063 in

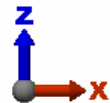
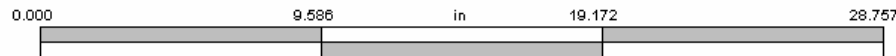

07093 Scenario 4 - Side

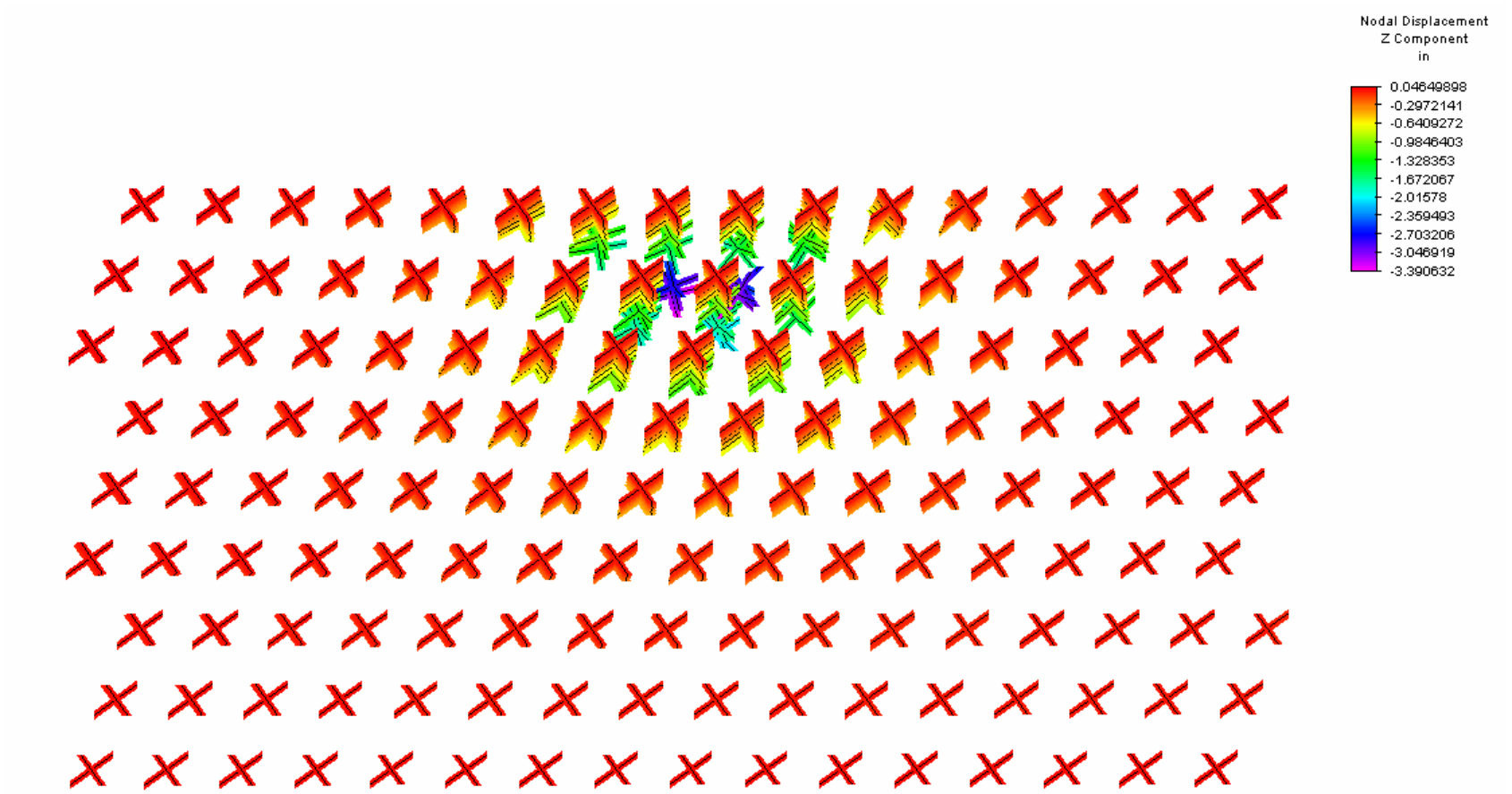

Load Case: 1 of 1

Maximum Value: 0.046499 in

Minimum Value: -3.39063 in

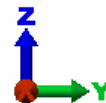
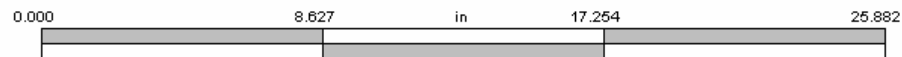

07093 Scenario 4 - Top

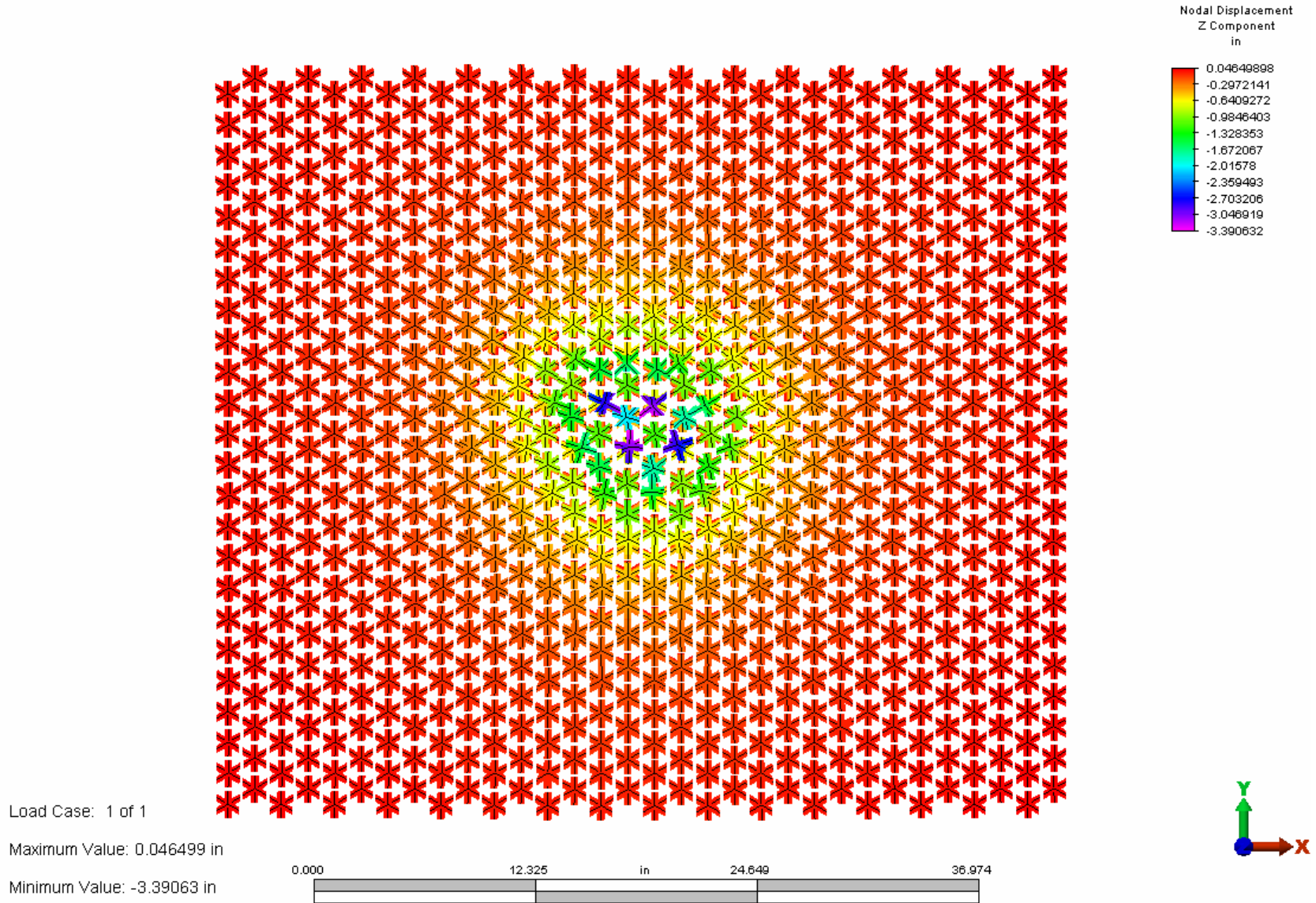

07093 Scenario 14 - Front

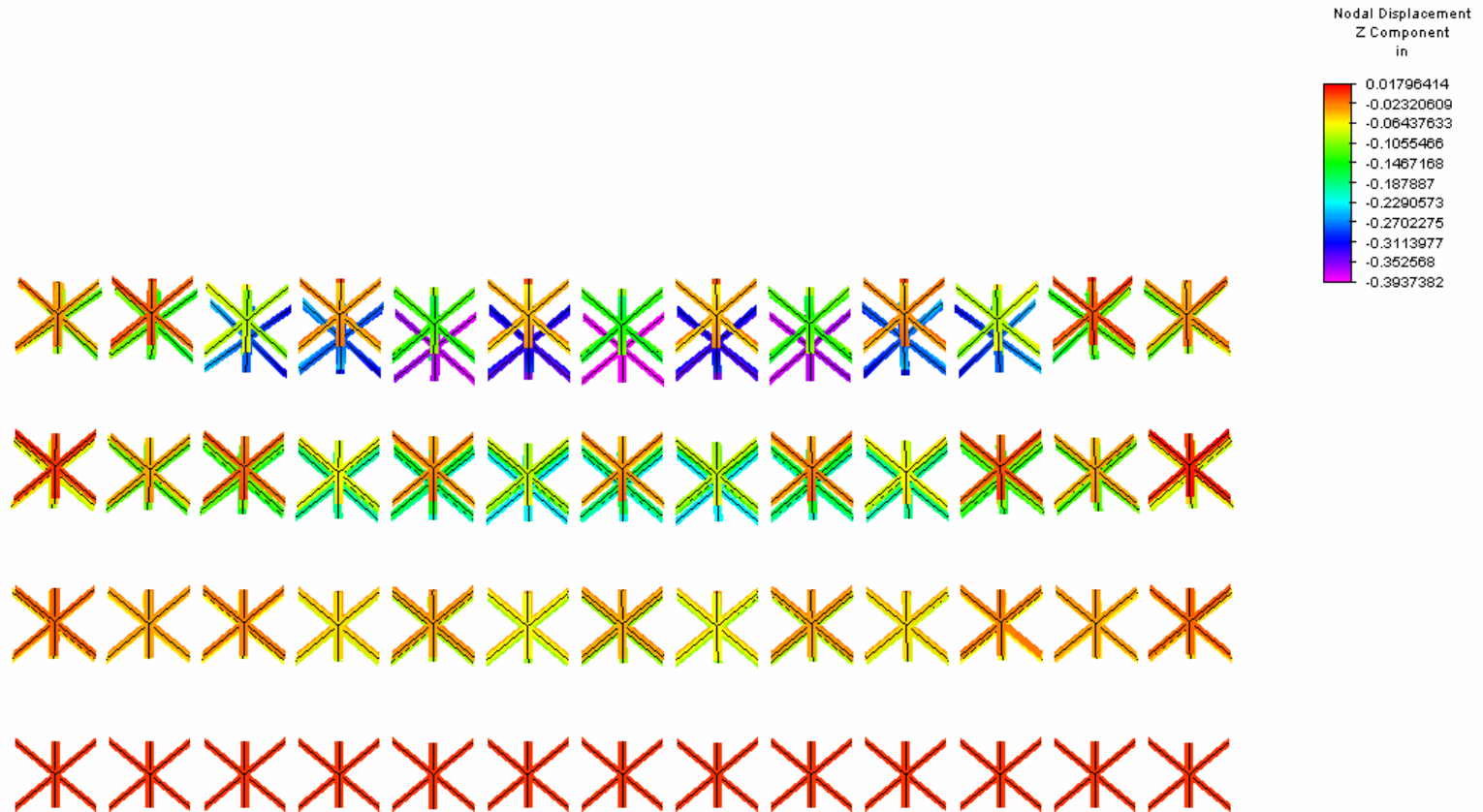

Load Case: 1 of 1

Maximum Value: 0.0179641 in

Minimum Value: -0.393738 in

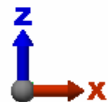
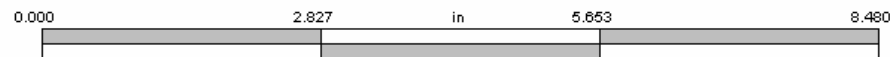

07093 Scenario 14 - Side

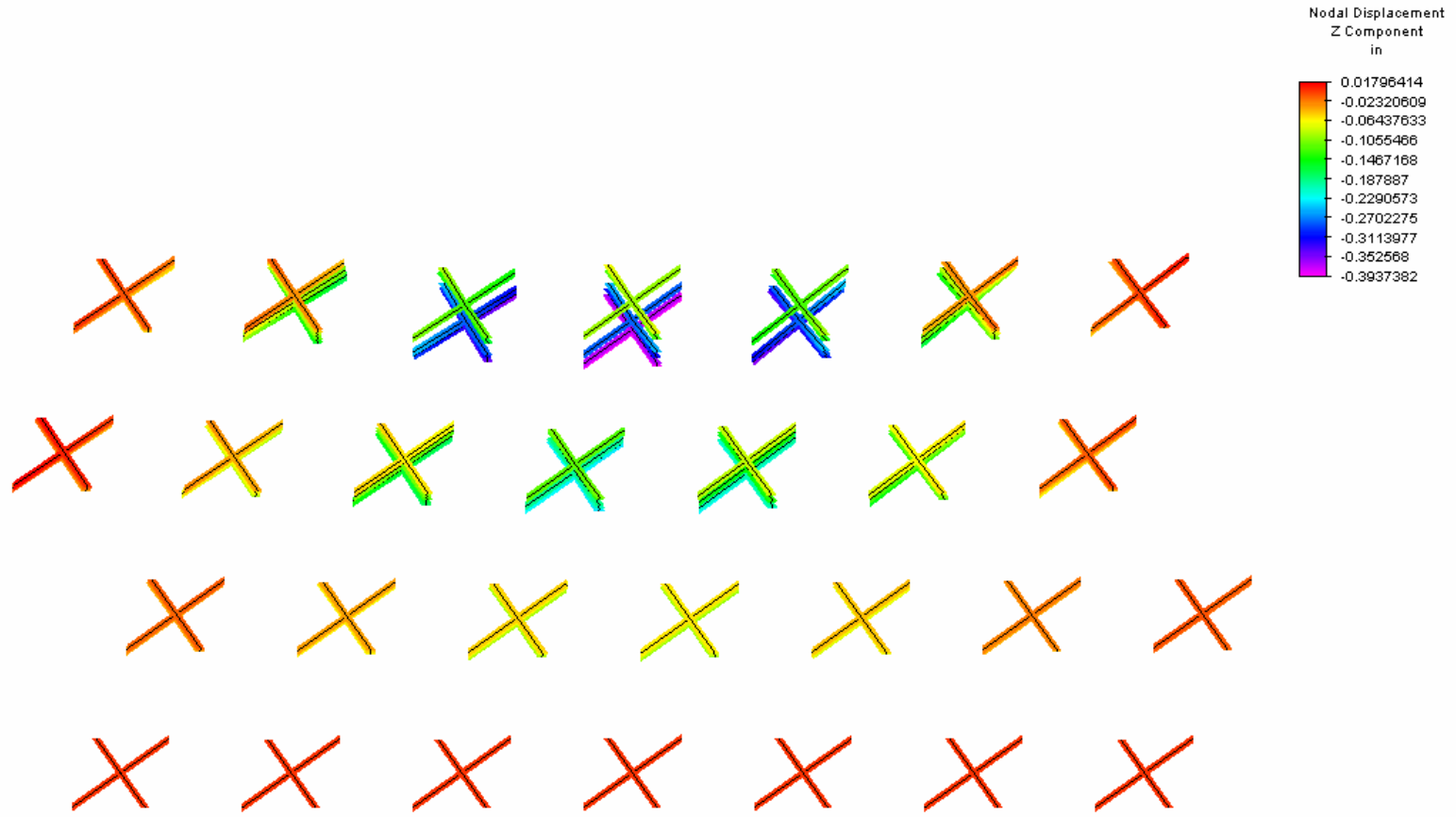

Load Case: 1 of 1
 Maximum Value: 0.0179641 in
 Minimum Value: -0.393738 in

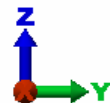
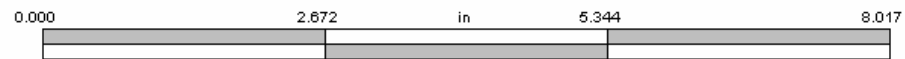

07093 Scenario 14 - Top

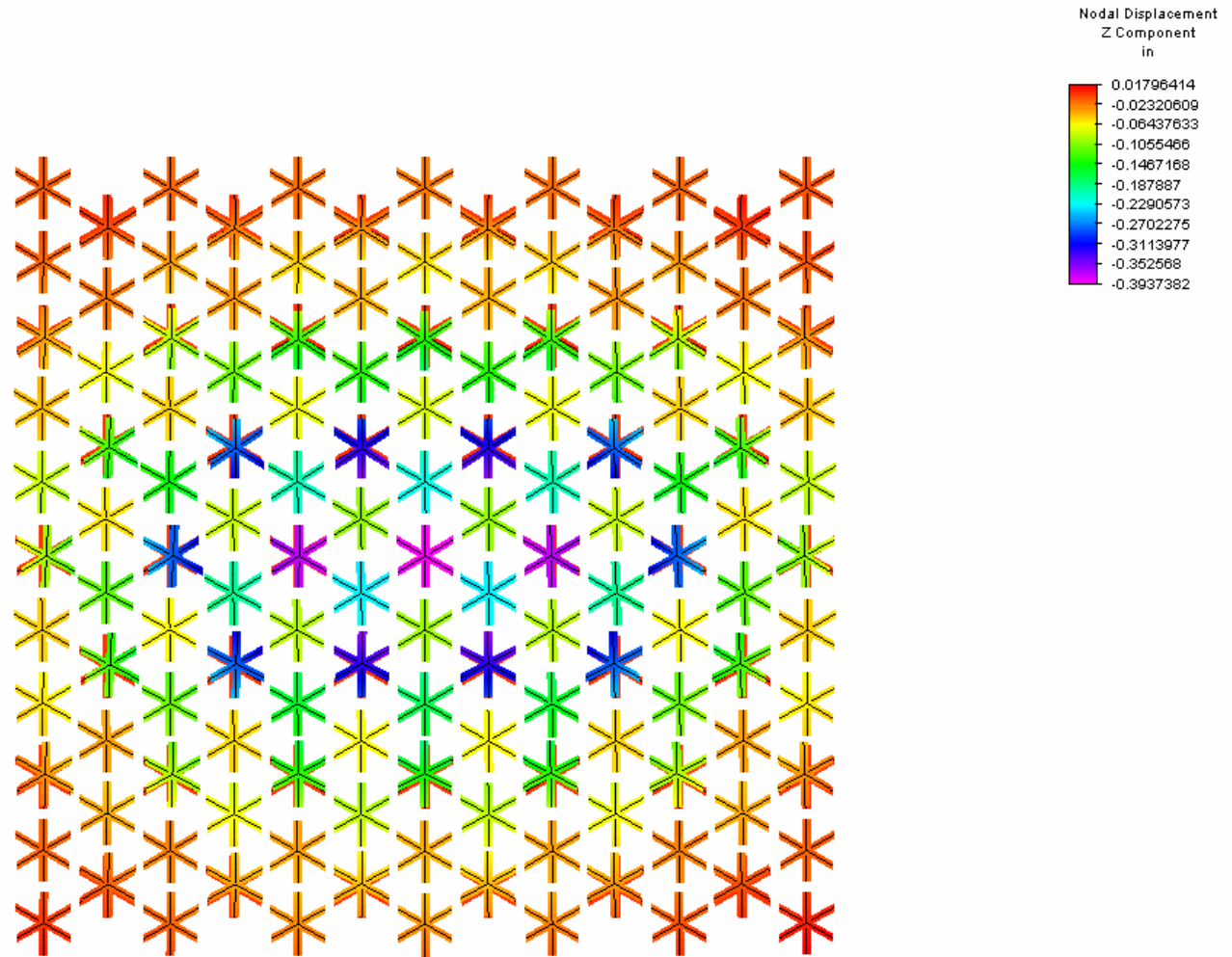

Load Case: 1 of 1

Maximum Value: 0.0179641 in

Minimum Value: -0.393738 in

